



COURTHOUSE ACCESSIBILITY

STANDARDS & BEST PRACTICES
FOR PROVIDING ACCESS TO ALL

PRESENTED BY
DISABILITY RIGHTS MISSISSIPPI
MISSISSIPPI ACCESS TO JUSTICE COMMISSION



MISSISSIPPI
Access to Justice
COMMISSION

JUSTICE *for* ALL

Including individuals with disabilities among people who count in composing "We the People," Congress understood in shaping the ADA, would sometimes require not blindfolded equality, but responsiveness to difference; not indifference, but accommodation.

Justice Ruth Bader Ginsburg, concurring in *Tennessee v. Lane*,

May 17, 2004

JUSTICE IS FOR EVERYONE

Access to justice is a fundamental right, and the ability to access justice is of critical importance, as well as a prerequisite for the protection and enjoyment of all other human rights. Access to justice is the equal ability to fully be heard and to participate in all aspects of the justice system without discrimination on the basis of disability. Unfortunately, the promise of "justice for all" continues to be elusive for people with disabilities.

WHY ACCESSIBILITY IS IMPORTANT

People with disabilities constitute the largest minority in the country.

At the time of the 2010 census, 54 million people (about 1 in every 5 people in the United States) had a disability that significantly limited one or more major life activities, such as walking, seeing, hearing, breathing, and thinking. Of that number, 7 percent used wheelchairs, and 2.1 percent used crutches, canes, walkers, or other assistive devices. Seventy-five percent have disabilities that are not obvious at first glance.

Additionally, the population of the United States is aging. By the year 2030, more than 80 million people will be 65 or older. As people age, impairments are more likely to hinder activities. The longer people live, the more likely they will be to have a disability.

To be fully included in society, persons with disabilities need access to justice. As long as they face barriers to their participation in the justice system, they will be unable to assume their full responsibilities as members of society or fully realize their rights. For this reason, it is important that barriers be removed so that persons with disabilities can enjoy the equal opportunity to perform their duties as witnesses, jurors, lawyers, judges, arbitrators, and other participants in the administration of justice.

INTRODUCTION

The Americans with Disabilities Act (“ADA”) defines an individual with a disability as a person who has a physical or mental impairment that substantially limits one or more major life activities, a person who has a history or record of such an impairment, or a person who is perceived by others as having such an impairment.

State Courts are covered by:

Title II of the ADA, 42 U.S.C. §§ 12131 – 12134, and its implementing regulations, 28 C.F.R. § 35.104

Almost every activity of a state court is ADA-covered:

- The juror selection system
- Trials
- Hearings
- Courthouse security procedures
- Access to libraries, publications, websites, dispute resolution programs, and seminars offered by the court
- Even if a trial or hearing is closed to the public, Title II applies if one of the participants has a disability. Title II also applies to the physical accessibility of courtrooms and courthouse structures.

The ADA Accessibility Guidelines (“ADAAG”) provide “the objective contours of the standard that architectural features must not impede an individual with disabilities the full and equal enjoyment of accommodations. If a barrier violating these standards relates to a plaintiff’s disability, it will impair the plaintiff’s full and equal access, which constitutes ‘discrimination’ under the ADA.”

Common Misconception:

City governments may believe that their existing programs and facilities are protected by a "grandfather" clause from having to comply with the requirements of Title II of the ADA. Small municipalities may also believe that they are exempt from complying with Title II because of their size.

Because city governments incorrectly believe that a "grandfather" clause or a small entity exemption shields them from complying with Title II of the ADA, they fail to take steps to provide program access or to make modifications to policies, practices, and procedures that are required by law. People with disabilities are often unable to gain access to city facilities, programs, services, or activities because of a public entity's reliance on these common misconceptions.

Reality: There is no "grandfather" clause in the ADA. Facilities used by the public must be accessible. However, the law is flexible. City governments must comply with Title II of the ADA, and must provide program access for people with disabilities to the whole range of city services and programs. In providing program access, city governments are not required to take any action that would result in a fundamental alteration to the nature of the service, program, or activity in question or that would result in undue financial and administrative burdens. This determination can only be made by the head

of the public entity or a designee and must be accompanied by a written statement of the reasons for reaching that conclusion. The determination that undue burden would result must be based on all resources available for use in a program. If an action would result in such an alteration or such burdens, a city government must take any other action that it can to ensure that people with disabilities receive the benefits and services of the program or activity.

This manual is intended to assist in breaking down the expansive laws, regulations, and requirements in an effort to provide a tool for courthouse executives and employees across the state to readily answer questions, self-evaluate and ultimately create a more inclusive justice system in Mississippi. Key points, statements, interpretations will be provided, followed by a reference if a user needs to look up the specific law. This manual contains recommendations for guidance on accessible courthouse design under the Americans with Disabilities Act and the Architectural Barriers Act. This is not a regulation, rather a tool for evaluation of equal access to the judicial process for all Mississippians.

Disability is a natural part of life. Some people acquire disabilities at birth, such as cerebral palsy, while others acquire them later in life, such as severe arthritis or low vision. Some people have obvious disabilities such as blindness, while others experience “hidden” disabilities such as diabetes, deafness, HIV infection, and epilepsy. Some individuals experience disability on a temporary basis, such as during cancer treatment, while others have permanent or progressive disabilities.

At any time, people with disabilities may come into contact with our court system as jurors, parties, witnesses, observers, or community members. More and more frequently, people with disabilities are serving as lawyers, clerks, court reporters, mediators and judges in state court systems.

Some individuals with disabilities are able to take part in various court processes and activities without difficulty. For many others, a disability, combined with environmental obstacles, imposes significant barriers to an equal opportunity to participate. The courts have an affirmative obligation to identify and remove these barriers so that people with disabilities can access court programs and services, including judicial proceedings, jury service, and courthouse meetings.

ABOUT DRMS

Disability Rights Mississippi is a private, nonprofit organization with a federal mandate to protect and advocate for the rights of Mississippians with disabilities. Since 1982, DRMS has provided legal advocacy services, free of charge, and improved the lives of our state's most vulnerable population by championing their rights.

The mission of Disability Rights Mississippi is to promote, protect, and advocate for the rights of all people with disabilities and to assist them with full inclusion in home, community, education, and employment.

ABOUT THE MISSISSIPPI ACCESS TO JUSTICE COMMISSION

Recognizing the need for a single unifying entity to bring together the various providers of civil legal services, the Mississippi Supreme Court created the Access to Justice Commission in 2006. Funded through the generous support of the Mississippi Supreme Court, The Mississippi Bar and The Mississippi Bar Foundation, the Commission aims to make a difference for one, for all.

The mission of the Mississippi Access to Justice Commission is to develop a unified strategy to improve access to justice in civil legal proceedings for the poor in Mississippi.

Contents

ABOUT DRMS	4
ABOUT THE MISSISSIPPI ACCESS TO JUSTICE COMMISSION	4
RECOMMENDATIONS FOR ACCESSIBLE COURTHOUSE ENTRY – THE EXTERIOR.....	7
I. PARKING.....	7
II. EXTERIOR SIGNAGE.....	10
IV. EXTERIOR RAMPS AND CURB RAMPS.....	13
V. COURTHOUSE ENTRANCES	21
VI. ACCESSIBLE MEANS OF EGRESS.....	23
VII. METAL DETECTORS AND X-RAY MACHINES.....	24
VIII. MANEUVERING DISTANCES	24
IV. THRESHOLDS	26
X. DOORS AND DOORWAYS.....	27
XI. CLEARANCES	29
XII. STAIRWAYS AND HANDRAILS.....	31
THE INTERIOR:	35
LOBBY WAITING AREAS.....	35
COURTROOM, ADDITIONAL ROOMS, AND ENTRY	35
Courtroom Entry.....	35
Seating:.....	36
Rail (Bar).....	37
Jury Box.....	37
Witness Stand.....	38
Judge’s Bench.....	38
Clerk’s and Bailiff’s Stations	38
Court Reporter Area	38
Furnishings.....	38
Judges’ Chambers.....	39
Jury Deliberation Suite	39
Holding Cells	40
Restrooms.....	40
Drinking Fountains	41
Accessible Routes	41
III. ACCESS TO EXITS.....	42

IV. INTERIOR AREA OF REFUGE	42
V. ACCESS TO RAISED ELEMENTS IN COURTROOMS AND COURTHOUSE.....	42
VI. DETERMINING ACCOMODATIONS FOR JUDICIAL ACTIVITIES.....	43
VII. CONSIDERATIONS FOR COURHOUSE EMPLOYEES AND STAFF WITH DISABILITIES	43
VIII. HISTORIC PRESERVATION	43
IX. SERVICE ANIMALS.....	44
X. ACCOMODATIONS FOR PEOPLE WITH LOW VISION OR BLINDNESS	45
XI. SIGN LANGUAGE INTERPRETERS.....	45
XII. ELECTION DAY ACCESSIBILITY	46
XIII. WEBSITE ACCESSIBILITY.....	47
GLOSSARY.....	48
ACCESSIBILITY LAWS, REGULATIONS, AND STANDARDS.....	50
References and Sources	53

RECOMMENDATIONS FOR ACCESSIBLE COURTHOUSE ENTRY – THE EXTERIOR

I. PARKING

State and local government agencies that offer programs, services, or activities in existing facilities need to make sure that people with disabilities can gain access and participate in these activities. Adding accessible parking is one step government agencies can take to ensure people with disabilities can participate.

A. Parking Spaces

- Must have at least 1 van accessible space per parking area, plus one accessible space per 25 parking spaces.
 - Accessible parking spaces are required based on the total number of parking spaces provided in each lot
 - Must be on shortest route to accessible entrance
 - If multiple accessible entrances exist, spaces must be evenly dispersed to them
 - Compliance is not necessary for parking spaces for buses, trucks, delivery vehicles, law enforcement vehicles, or impound lot
 - One of six accessible parking spaces, but always at least one, must be van-accessible
 - Accessible parking spaces, aisles, and routes must be maintained in good repair and kept clear of debris
 - In some cases, achieving the shortest accessible route will require locating accessible spaces closest to an entrance ramp instead of the entrance doors.
- Non van-accessible spaces must be at least 96 inches wide.
 - Van-accessible spaces must be at least 132 inches wide with an adjacent 60-inch wide minimum access aisle
 - A van parking space of 96 inches wide minimum width an adjacent 96-inch wide minimum access aisle is also permitted
- Van spaces provide an additional 3 feet of width to accommodate vehicles equipped with ramps or lifts
 - A wider access aisle saves space since two spaces can share one aisle, but wider spaces can help prevent misuse of the access aisle as a parking space
 - Access aisles may be located on either side of the parking space except for angled van parking spaces which must have access aisles located on the passenger side of the parking spaces
 - In parking garages, van-accessible spaces and access aisles must also provide vertical clearance of at least 98 inches to accommodate the height of most vehicles that are equipped with wheelchair lifts
- Accessible spaces required for one parking facility can be located in another if doing so results in substantially equal or better access in terms of travel distance to an accessible entrance, parking fee, or user conveniences such as protection from weather, better security and lighting
 - Parking sites are considered separate if they are in different locations or separated by a barrier such as a fence

- An accessible route must always be provided from the accessible parking to the accessible entrance

B. Access Aisles

An access aisle provides space for an individual with a disability to transfer between a vehicle in the accessible space and a mobility device, like a wheelchair or scooter. It is important to keep an access aisle clear so it can be used for its intended purpose.

- An access aisle of at least 60 inches is required on either side of the parking space
- Two spaces can share one aisle
- Boundary of the access aisle must be clearly marked so as to discourage parking in it
- Alterations, remodel, additions, new construction:
 - If and when a facility or business restripes its parking lot, it **MUST** provide accessible parking spaces as required by the ADA Standards for Accessible Design. ADA states that barriers to access in existing parking lots must be removed, when it is readily achievable to do so.

Accessible spaces are required where parking facilities are altered or added. The term ‘alterations’ includes resurfacing of vehicular ways (§106.5). Resurfacing or resealing and projects that add new parking spaces constitute alterations (or additions) and must include accessible spaces as required in the scoping table. Normal maintenance, such as pothole repair, surface patching, or repainting in place existing striping for a few spaces, is not considered an alteration except where it affects a facility’s usability. The following diagram shows how the facility's parking lot may be set up to comply with regulations.

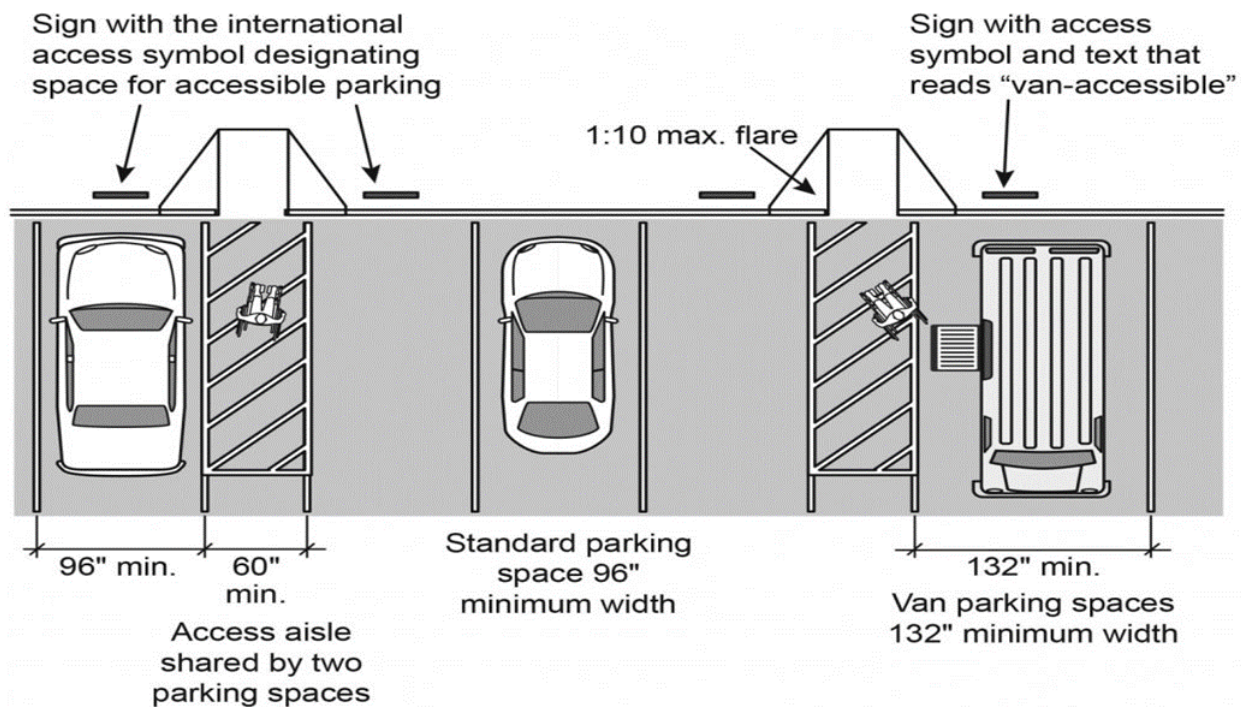

Parking Spaces and Access Aisles

C. Surfaces and Pavement

Rough and uneven surfaces make it difficult to push a wheelchair, maintain balance, or use other devices to help with mobility. Ensuring that parking lots, sidewalks and areas surrounding the courthouse meet required standards is one step government agencies can take to ensure people with disabilities can participate.

- Accessible floor and ground surfaces must be stable, firm, and slip resistant.
 - Meaning that accessible surfaces remain unchanged by external forces, objects, or materials
 - Surfaces should not have any abrupt change in slope or level
- Accessible surfaces must be slip resistant to minimize hazards to people with disabilities, especially those who are ambulatory or semi-ambulatory or who use canes, crutches, and other walking aids.
 - Compliance with the standards requires specifying surface materials, textures, or finishes that prevent or minimize slipperiness under the conditions likely to be found on the surface.
 - **Slip resistance:** There should be adequate traction so the wheels can get a firm grip on the floor without slipping or skidding. A textured or otherwise slip-resistant surface is necessary and is especially helpful if the floor might ever encounter moisture, such as in a bathroom.
 - **Firmness:** The floor should not dent or compress under the weight of a wheelchair.
 - **Stability:** The floor should be bonded to the subfloor, without the risk of sliding, detaching, or folding over on itself as a wheelchair moves over it.
 - **Smoothness:** While the floor does need some texture on the surface to provide traction, it cannot be too uneven or bumpy, since this will make it difficult to navigate over. For example, a cobblestone surface would not be wheelchair accessible.
- Avoid materials or construction methods that create bumpy and uneven surfaces in areas and along routes required to be accessible.
 - Rough surfaces composed of cobblestones, Belgian blocks, and similar materials can be difficult and sometimes painful to negotiate with wheeled mobility aids due to the vibrations they cause.
- Openings in floor or ground surfaces must not allow passage of a sphere that is more than 1/2" diameter.
 - Consideration must be given to whether or not a wheelchair caster could become lodged in the opening

Accessible parking spaces must be no less than eight feet wide. Van-accessible spaces must be no less than 11 feet wide. Van-accessible spaces may be eight feet wide if their access aisles are also eight feet wide. If there is only one accessible space, it should be van-accessible. Accessible spaces must provide adjacent access aisles that are no less than five feet wide. These aisles are intended to provide sufficient room for individuals to load and unload wheelchairs, scooters, and other mobility devices, and to deploy those devices as needed. The surfaces of parking lots and areas of traverse to access a courthouse must be smooth, with consideration given to safety as well as accessibility.

II. EXTERIOR SIGNAGE

Creating an ADA compliant parking lot is crucial for providing ample access to every individual, and it requires proper sizing, placement and marking of parking spaces reserved for those who need them. Section 502.6 of the 2010 Standards provides that accessible parking spaces must be identified by signs that include the International Symbol of Accessibility.

The International Symbol of Access, also known as the Wheelchair Symbol, as seen below, consists of a blue square overlaid in white with a stylized image of a person in a wheelchair.



Updated Dynamic
Accessibility Symbol



Original
Accessibility Symbol

- Accessible spaces must be identified by signs with the International Symbol of Accessibility (ISA) (§703.7.2.1). The diagram below provides a visual of these requirements.
 - Signs identifying van spaces must include the term “van accessible.”
 - Van accessible sites are not exclusively for vans. Van accessible parking spaces can be used by either vans or cars showing the proper plate or placard
- Signs must be at least 60” high measured to the bottom edge so that they are visible while vehicles are parked in a space.
 - ADA parking signs (commonly known as Access Signs) posted must be visible from the driver's seat of the vehicle and located right in view of parking spaces
 - Signs should be mounted so that the lower edge of the sign is at least five (5) feet above the ground. This helps ensure visibility both for motorists and local enforcement officials
 - Surface decals or other identifying features may be required by local or state codes and can be provided in addition to, but not in place of, signs required by the ADA Standards

- At inaccessible entrances, signage is required to direct people to the accessible entrance.
 - Signs with the ISA symbol to provide direction should be in an obvious and conspicuous location
 - Accessible entrances for people with disabilities improves access for everyone. Making public spaces and facilities physically accessible for people with disabilities also makes them more accessible for people who may not have visible disabilities or have other needs

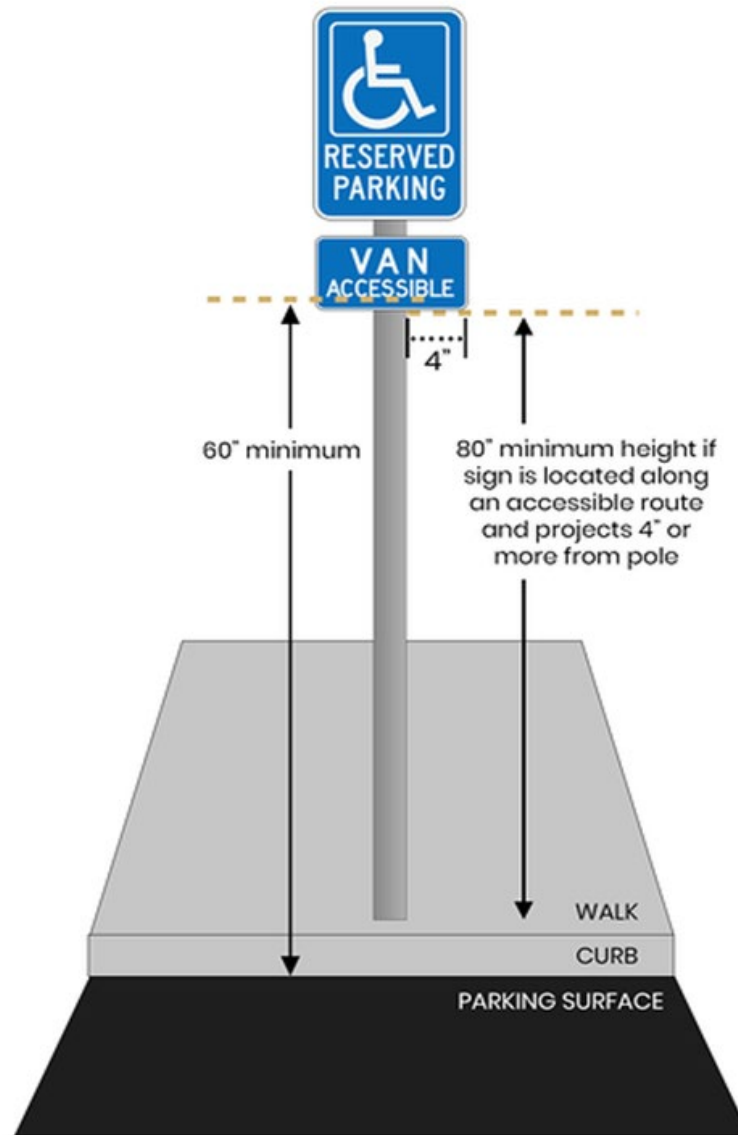

III. SITE ARRIVAL POINTS & DROP-OFF ZONES

- The site arrival point must be as close as possible to an accessible entrance while allowing for security measures.
 - The exterior route should provide a safe and integrated way for people with disabilities to access the courthouse.

- Drop off areas should provide a clear, level entry to the accessible entrance route established for the courthouse.
- At least one accessible route must be provided within the site to accessible facility entrances from these site arrival points, where provided:
 - accessible parking and accessible passenger loading zones
 - public streets and sidewalks
 - each public transportation stops

Site arrival points include accessible parking spaces and accessible passenger loading zones, public transit stops located on sites, and public streets and sidewalks.

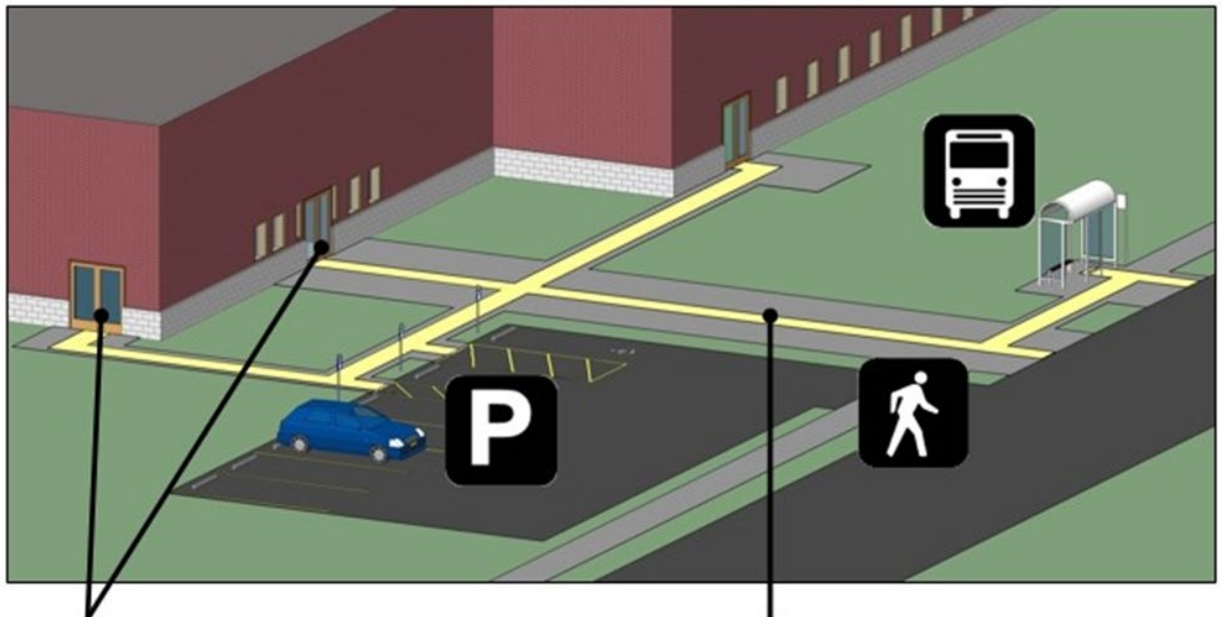

An accessible route must connect site arrival points to each accessible entrance they serve.

Accessible routes must coincide with, or be in the same vicinity as, general circulation paths (§206.3).



If no pedestrian route onto a site is provided and site entry is by vehicle only, an accessible route from the site boundary is not required (§206.2.1, Ex. 2). Where a vehicular way does provide pedestrian access, such as a shopping center parking lot, an accessible route is required.

- Though not required, a passenger drop-off area is often needed for individuals with mobility impairments who may find travel distances from parking areas excessive.
 - Where practical, and in climates with inclement weather, it is desirable to provide overhead protection from the curb to the entry.
- Where there is a passenger loading zone, at least one accessible point must be present.
 - Compliance is only necessary in areas specifically designed for passenger loading/unloading.

- Where a passenger loading/drop-off zone is provided, an access aisle that is 60 inches wide and the same length of the vehicle pull-up space must be provided adjacent and parallel to the zone.
- All passenger loading zones are required to be accessible. It is common to assume that prisoners with disabilities do not need a barrier-free path because they are always under guard supervision. However, prisoners need to be afforded the same mobility independence whether or not they have a disability.

IV. EXTERIOR RAMPS AND CURB RAMPS

- The exterior accessible route must be at least 36 inches wide, no steeper than a grade of 1:20 (for a ramp, a maximum grade of 1:12)
- Portions of accessible routes with running slopes steeper than 5% also must be treated as ramps.
- Elevators and, under certain specified conditions, platform lifts, can be used as an alternative.
- Slope represents the proportion of vertical rise to horizontal length and is specified in the Standards as a ratio (e.g., 1:12).
 - It also can be expressed as a percentage, pitch, or in degrees.

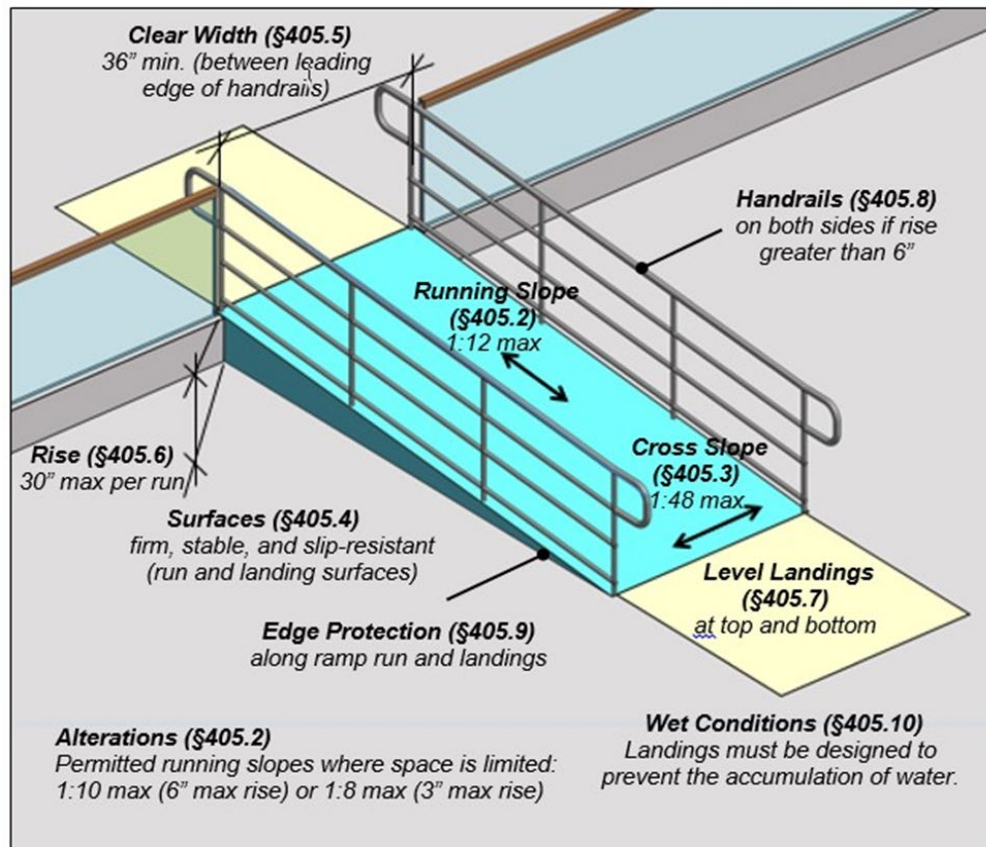

- The running slope is to be uniform along a run, although slight variations may occur with certain materials such as concrete.

- No other changes in level other than the running slope (1:12 max.) and cross slope (1:48 max.) are permitted
- Providing the least possible slope below the 1:12 (8.33%) maximum offers better usability for a wider range of users.
 - Specifying a running slope of 7.5% maximum and a cross slope of 1.5% maximum for exterior ramps will accommodate most irregularities or variances due to construction methods or materials.
- Ramp runs must have a clear width of 36" minimum (measured between handrails where provided).
 - The width of ramps that are part of a means of egress may further be determined by applicable life safety codes and requirements for minimum exit widths greater than 36"
- The height of runs is limited (30" max.), but there is no limit on the number of runs a ramp may have.
 - Long ramps with many runs can be strenuous for people using manual wheelchairs
 - While intermediate landings offer resting points, they do not reduce the amount of effort that must be exerted to negotiate multiple runs
- Level landings are required at the top and bottom of each run. Changes in level greater than 1:48 are not permitted at landings.
 - Landings must be designed to prevent the accumulation of water

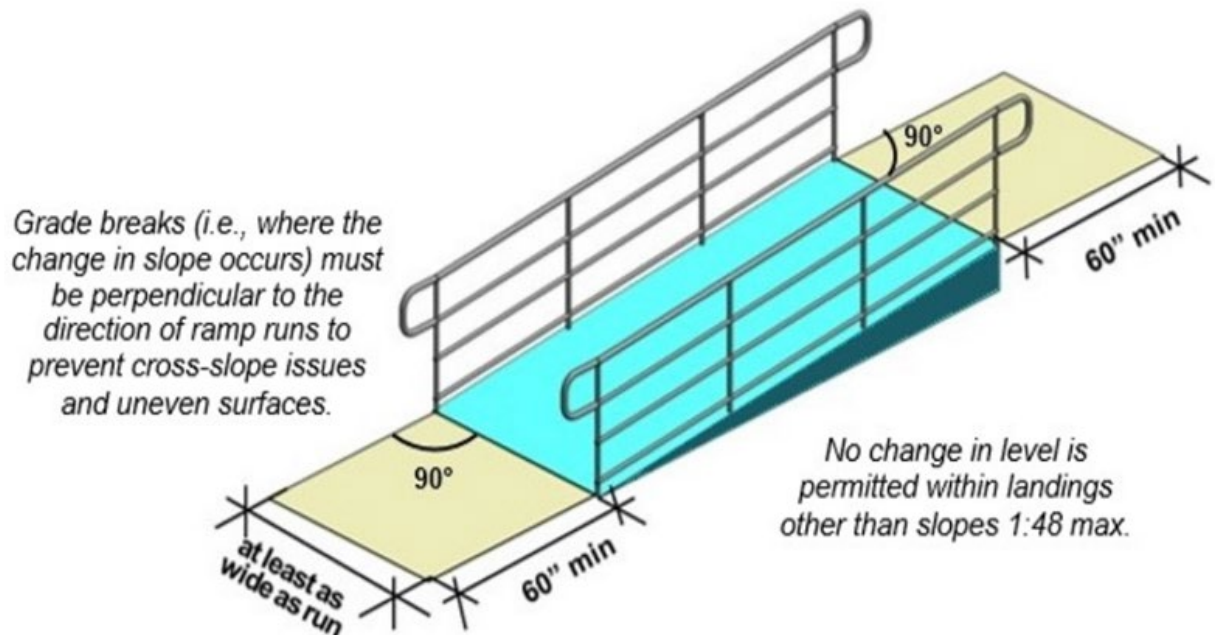

- Intermediate landings between runs must be at least 60" wide clear and 60" long clear where ramps change direction (any change from linear).
- Handrails, edge protection, vertical posts and other elements cannot obstruct or overlap the minimum 60" by 60" clearance.

- The 12" minimum handrail extensions required at the top and bottom of ramp runs must be be in the same direction of the run, but they can turn or wrap where handrails are continuous at the inside turn of dogleg or switchback ramps.
- Required door maneuvering clearances can overlap ramp landings (it is advisable to locate the swing of doors outside ramp landings for greater safety)

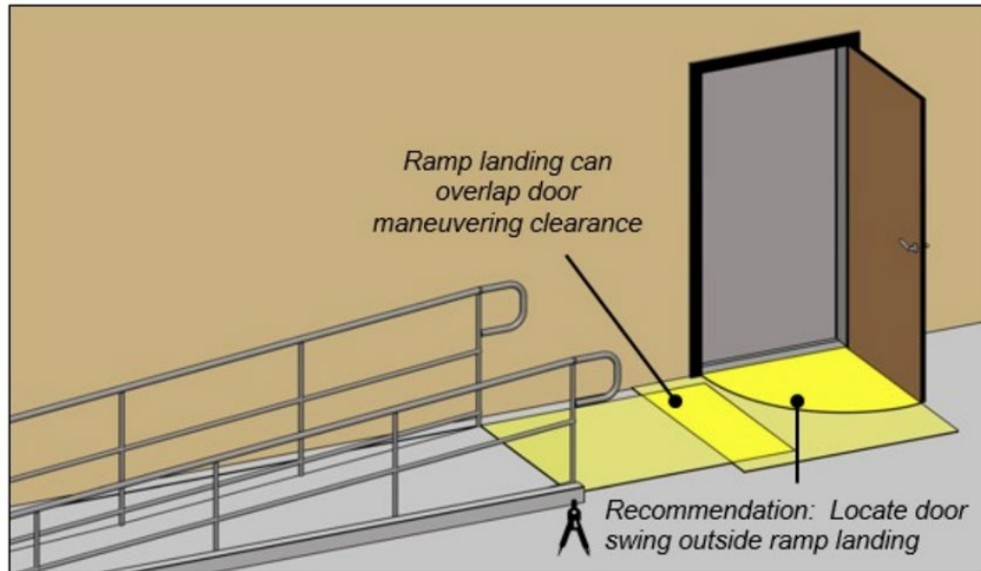

- Handrails are required on both sides of ramps with a rise greater than 6".

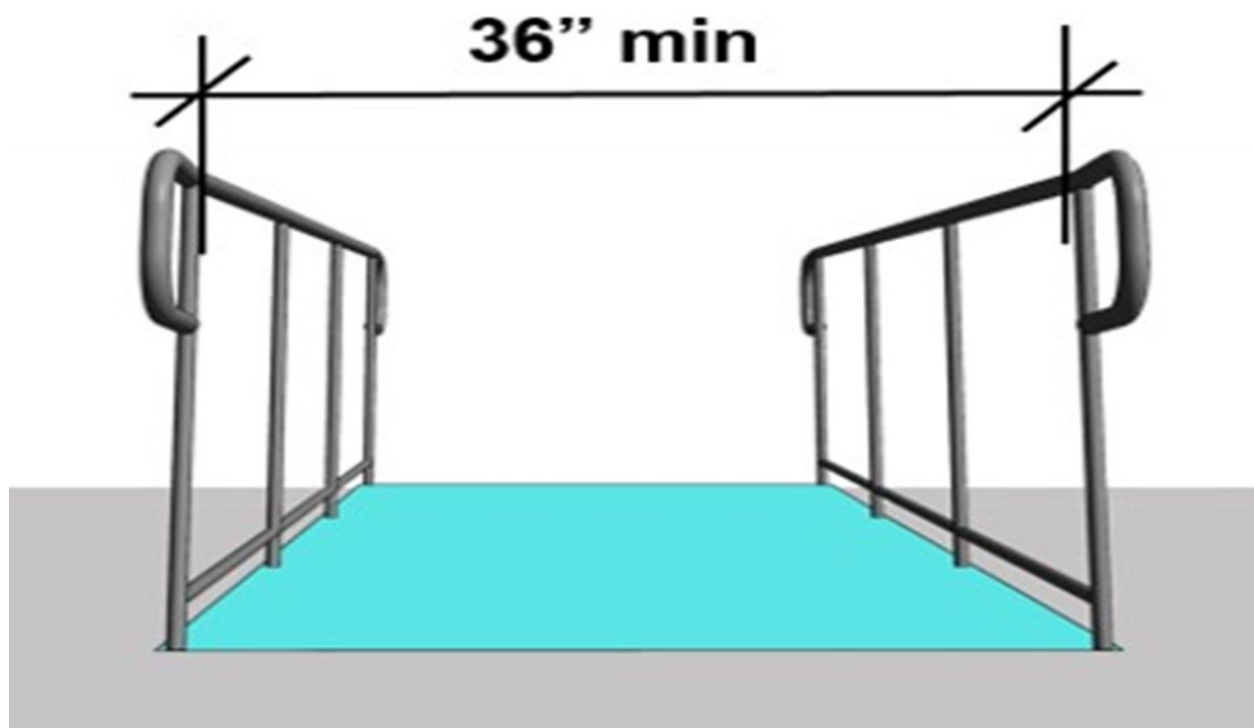

- Edge protection along ramp runs and landings keep wheelchair casters and crutch tips on the surface and can be provided by curbs, barriers, or extended surfaces.

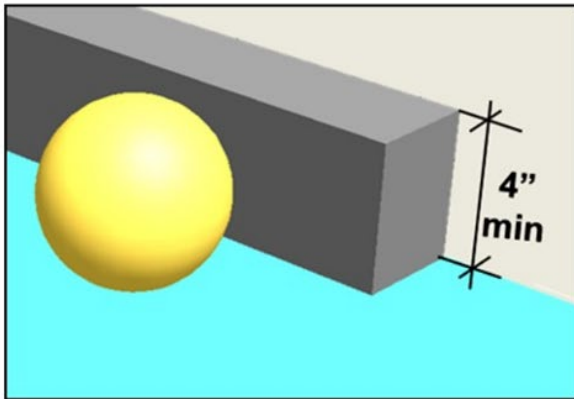

Curbs if used must be at least 4" high.

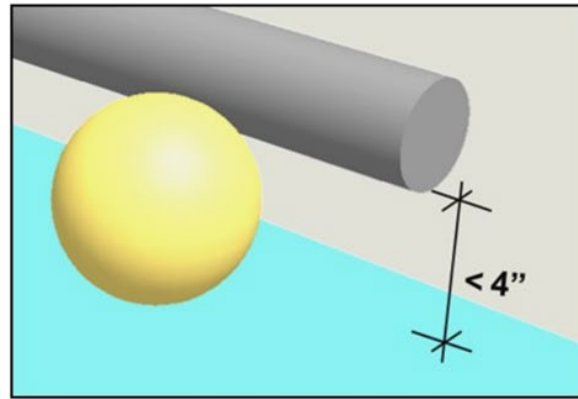

Rails or other barriers must prevent passage of a 4" diameter sphere.

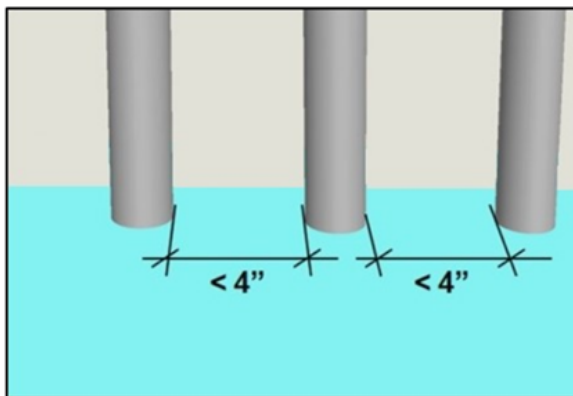

Vertical pickets used for edge protection must prevent passage of a 4" diameter sphere.

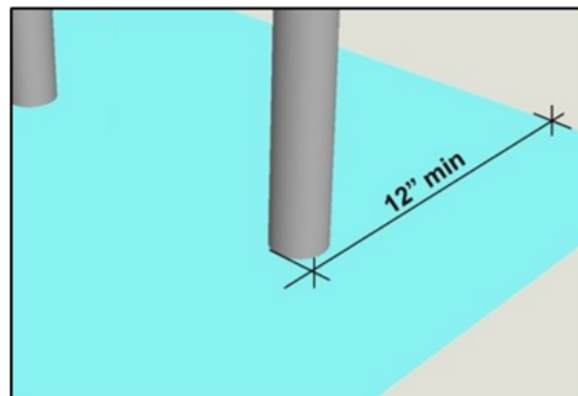

Run and landing surfaces that extend at least 12" beyond the inside face of handrails will provide adequate edge protection by preventing wheelchair casters and crutch tips from slipping off the edge.

- Edge protection is not required at:
 - ramps no higher than 6" that have side flares;
 - ramp landings serving an adjoining run or stairway;

- sides of ramp landings with vertical drop-offs not exceeding 1/2" within 10" of the minimum landing area.
- Requirements for curb ramps apply to ramps that cut through curbs or are built up to them.
 - DOJ's 2010 ADA Standards require curb ramps at newly constructed or altered streets, highways, and street-level pedestrian walkways to provide an accessible route for pedestrians at intersections.
- The required landing at the top of curb ramps allows an accessible route to connect to the ramp opening.
 - Side flares, where provided, are intended primarily to prevent tripping hazards, not to accommodate wheelchair maneuvering at ramps (except in alterations where sufficient landing space is unavailable).
 - Side flare slopes cannot exceed 1:10 max. (or 1:12 max. in alterations where a top landing is unavailable).

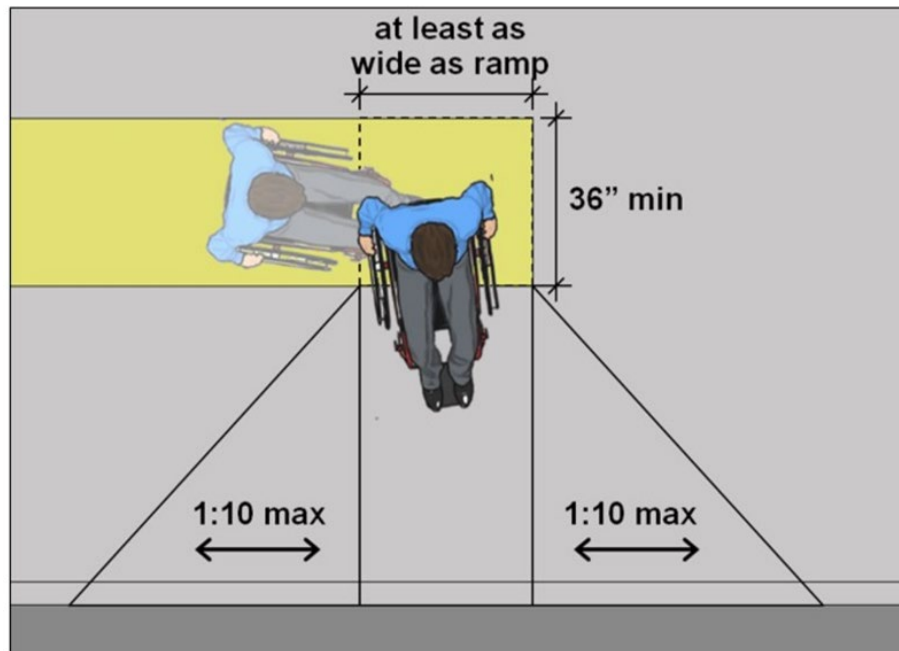

- In alterations where sufficient landing space is not available, side flares must be provided and cannot slope more than 1:12 to facilitate wheelchair maneuvering.
 - Parallel curb ramps provide an alternative in such conditions.

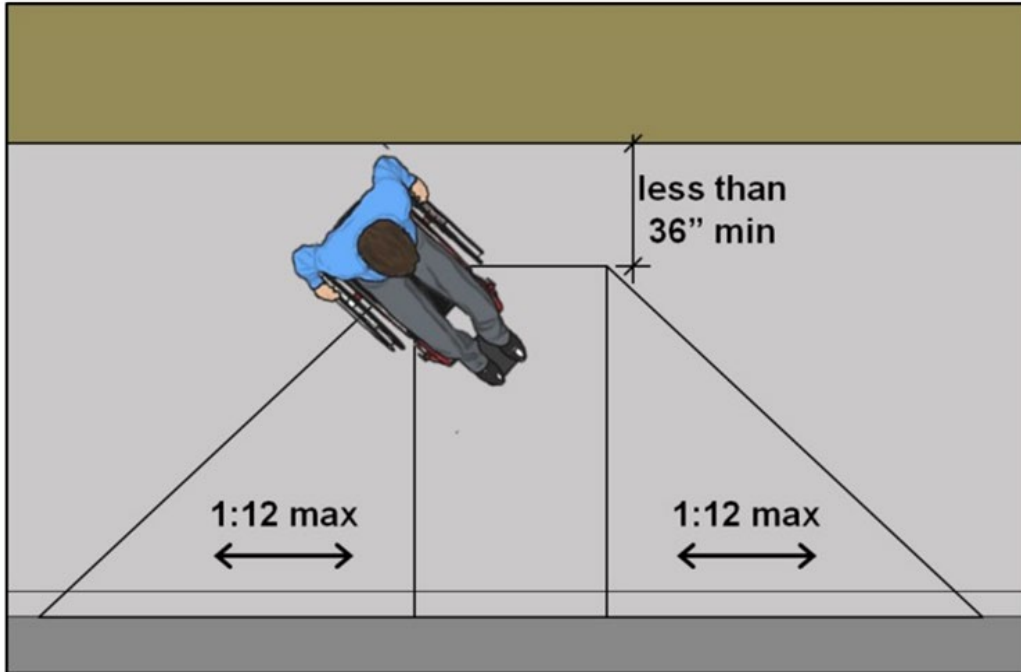

- The maximum slope of the top landing is determined by the configuration of connecting accessible routes.

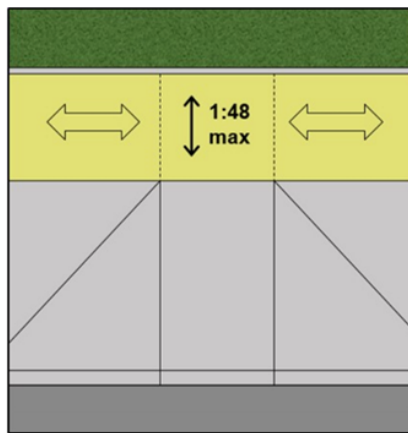

Perpendicular Accessible Route

The cross slope of perpendicular connecting routes limit the slope of route runs parallel to the ramp run, the ramp top landing to 1:48 (measured parallel to the running slope).

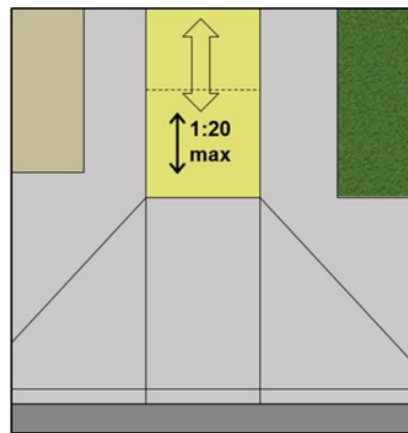

Parallel Accessible Route

If the only connecting accessible route runs parallel to the ramp run, the top landing can slope 1:20 max.

- Curb ramps can have returned sides, but a top landing is required under all conditions to allow maneuvering to and from the run.

- To prevent tripping hazards, curb ramps with returned sides should be used only where foot traffic across ramps is prevented or discouraged.

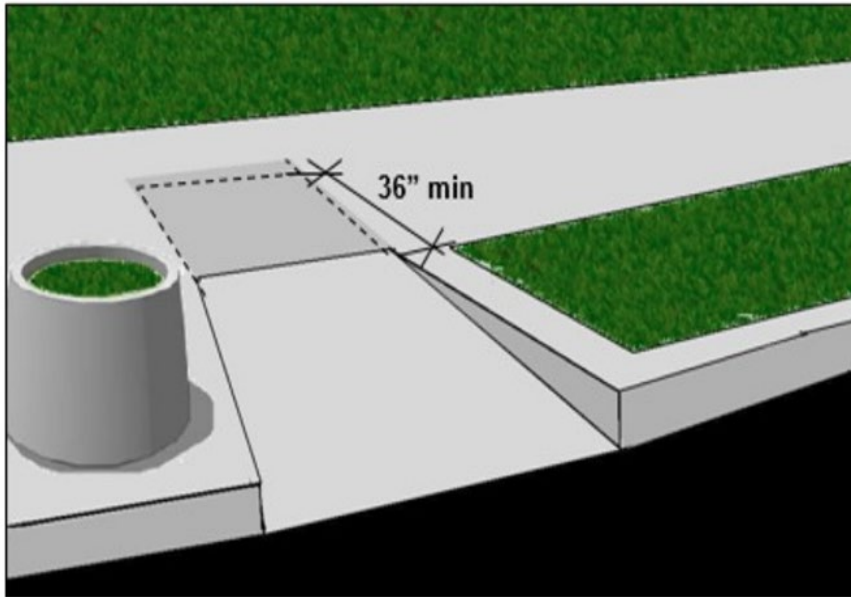

- Built-up curb ramps are permitted, but they cannot project in parking spaces, access aisles, or vehicle traffic lanes.
 - A top landing at least 36" deep is required at all built-up curb ramps.
- Provide edge protection along the sides of built-up curb ramps to prevent tipping hazards.
 - Otherwise, consider a wider ramp width (48" min.) so that maneuvering does not occur near drop-offs.

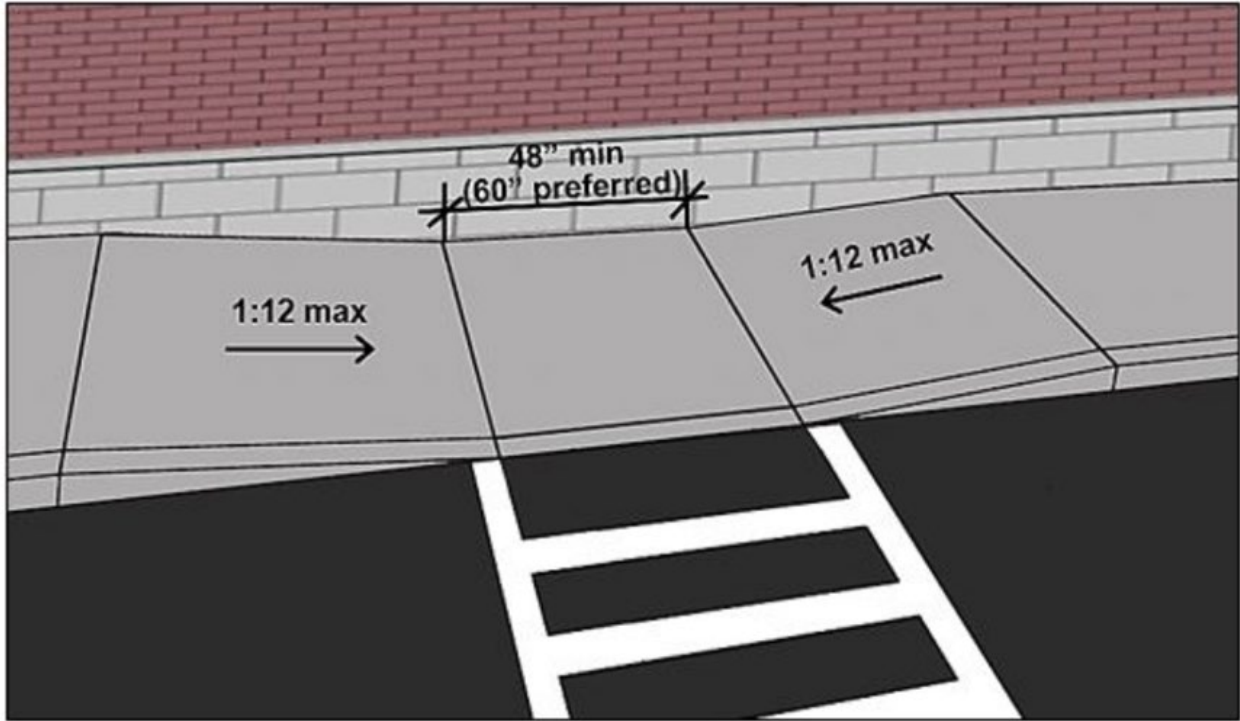

Best Practices for Ramps:

If a ramp is necessary, the slope should be as gradual as possible. The ramp should be wide enough to allow for companions who may be assisting individuals with mobility issues, thus exceeding the minimum width of 36 inches between the handrails. To provide integration, the ramp should begin with the general circulation path. Safety at all points should be the primary consideration.

Though not required, the following are best practices for the use of ramps:

- Ramps should not be located where they will be a tripping hazard for other circulation routes through the space.
- Ramps should not be located where they will block the means of egress, including maneuvering clearances at doors.
- Ramps should be located along the same path of travel as provided for the general population.
- When ramps are exterior, they should be located or designed to limit the accumulation of water, ice and snow.
- When ramps lead to doors that may be locked, a turning space should be provided at the door to allow someone to turn around if he or she cannot enter. This is also advisable at exterior doors because the force to open the door may be too high for some people with disabilities to operate.
- Handrails to provide stability for people with ambulatory impairments are recommended for all ramps, although they are not required if the ramp's rise is 6 inches or less.

V. COURTHOUSE ENTRANCES

A. Entrances

Courthouse entrances often serve different groups of users. Public entrances are used by spectators, visitors, witnesses, jury pool, attorneys, public safety officers, victim and witness advocates, and court employees. Restricted entrances are used by judges, jurors, public safety officers, victims, and court employees. Detainees enter the courthouse only via secure entrances. It is important that access is provided for each type of entrance, including public, restricted, and secure entrances.

- At least 60% of public entrances must be accessible. Public entrances are those entrances that are not a service entrance or a restricted/secure entrance.
 - At inaccessible entrances, signage is required to direct people to the accessible entrances
- At least one restricted entrance—which is an entrance that is made available for common use on a controlled basis, but not for public use, and that is not a service entrance—should be accessible.
 - This applies to those entrances where entry access is verified by security personnel and is strictly limited to certain occupants, but no one else, including guests or companions of authorized individuals.
- At least one detainee entrance should be accessible.
 - Doors operated solely by security personnel are exempt from the specific requirements for hardware, opening force, closing speed, and automation.
 - Only doors operated solely by security personnel qualify for this exemption.
 - Entrance doors operated sometimes by security personnel and sometimes by employees or the public must meet all requirements for accessible entrances.
- At least one accessible route must be provided within the site from accessible parking spaces and accessible passenger loading zones, public streets and sidewalks, and public transportation stops, to the accessible entrance(s) of the courthouse.

B. Accessible Routes

- At least one accessible route within the boundary of the site originating from site arrival points must connect all accessible buildings, facilities, elements, and spaces on a site.
- The accessible route must be the same path as the general circulation path.
 - Security barriers must not obstruct the pathway.
 - If the entranceway is not accessible, a sign indicating the direction of the accessible entrance must be present.
- At least one accessible door must be present at all accessible entrances.
 - At inaccessible entrances, signage is required to direct people to the accessible entrances
- Accessible routes can be adjacent to metal detectors and other screening devices that do not accommodate all people with disabilities, but the route must be located so users can maintain an equivalent level of visual contact with personal items.
- When security barriers are used (bollards, planters, etc.) there must be sufficient space between them for wheelchair clearance.
- If a circulation path is interior, the accessible route also must be interior.
- Accessible vertical interior circulation must be in the same area as stairs and escalators, not isolated in the back of the facility.

- Entrance landings must accommodate door maneuvering clearances as well as landings for provided ramps.

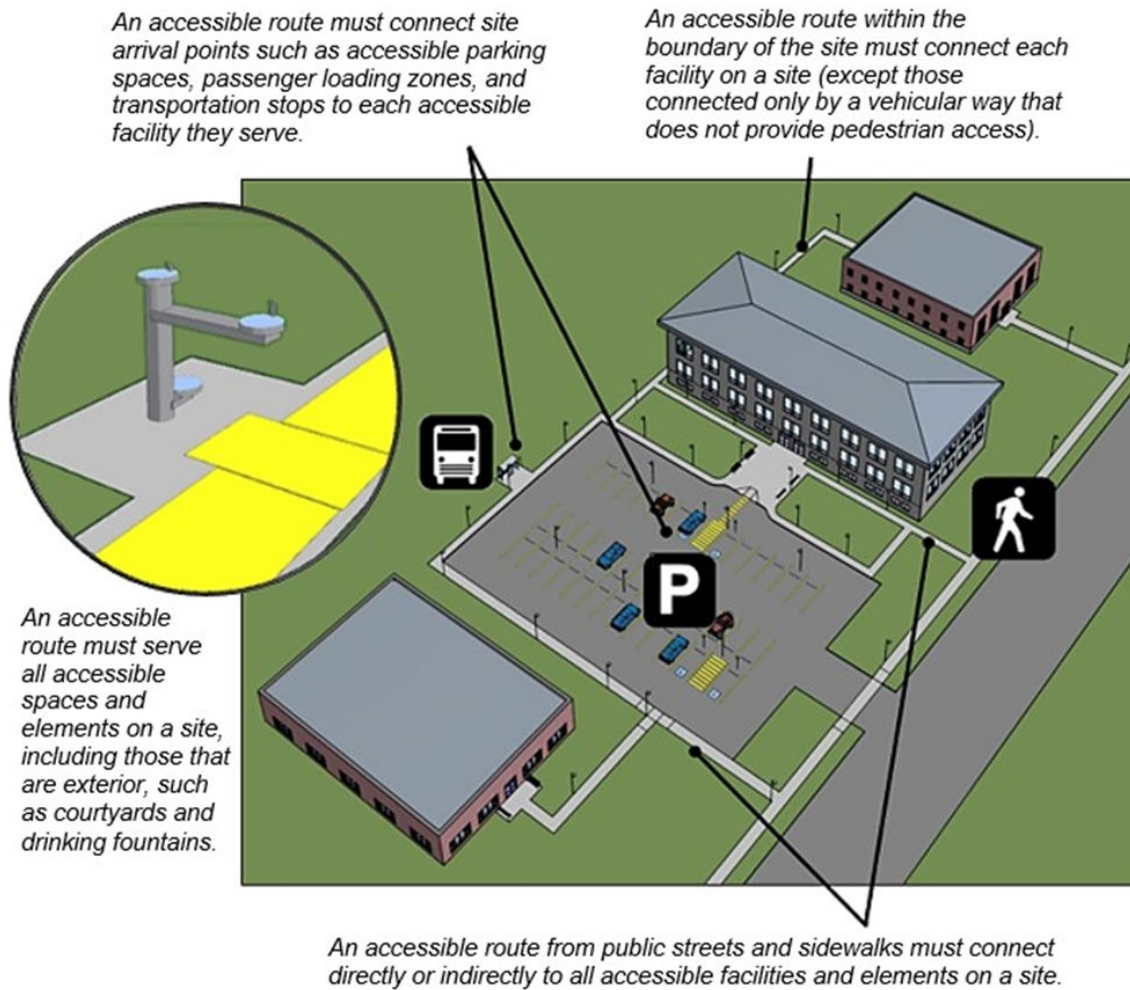

An accessible route is not required where the only means of access between buildings, facilities, or elements is a vehicular way not providing pedestrian access (§206.2.2, Ex.).

Accessible routes must coincide with, or be in the same area as, circulation paths. This promotes equivalency and precludes accessible routes that are obscure, hard to find, or that diverge from circulation paths more than is necessary (§206.3).

C. Two-Way Communication Systems

- Where two-way communication systems (i.e. those systems that may use call buttons, microphone/speaker systems, etc.) are provided to gain entry to a facility or to restricted spaces, they must include visual and audible signals to accommodate people with hearing, speech, or visual impairments.
 - This applies to all entrances equipped with such systems, including those that are inaccessible.
 - Lighted signals should have labels to indicate their meaning.

- If handsets are provided, cords must be at least 29” long.
- Control buttons and other operable parts must comply with those systems located at accessible entrances.

VI. ACCESSIBLE MEANS OF EGRESS

Egress is defined as the action of going out of or leaving a place. 2010 ADA Standard 106.5 defines Accessible Means of Egress as “a continuous and unobstructed way of egress travel from any point in a building or facility that provides an accessible route to an area of refuge, a horizontal exit, or a public way.”

An exit discharge is the path from an exit to a public way, such as a street, side-walk or alley.

The IBC requires at least two means of egress from all spaces and buildings with few exceptions. Some spaces and buildings are allowed to have one means of egress if the travel distance to an exit is short and the occupant load is low. A business occupancy with no more than 30 occupant load and a maximum exit access travel distance of 75 feet is permitted to have a single means of egress. More than two means of egress are required where the occupant load is 500 or more (at least 3) and 1,000 or more (at least 4).

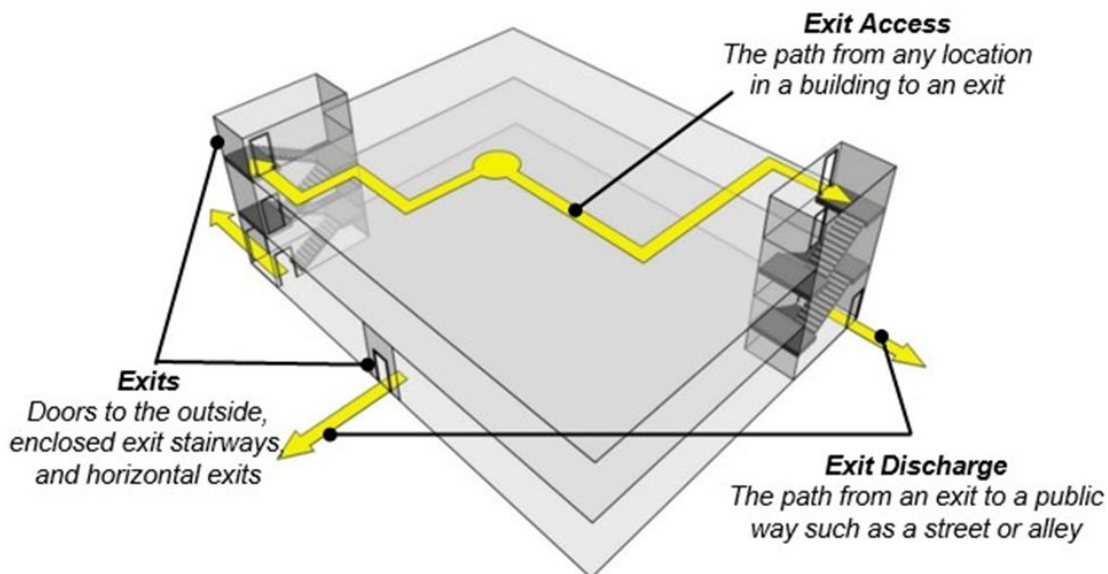

VII. METAL DETECTORS AND X-RAY MACHINES

Courthouses often have security at the entrances of the building. Many walk-through metal detectors cannot accommodate wheelchair traffic.

- An accessible route adjacent to the screening mechanism that is at least 36 inches wide is required where these stations are not accessible
- The accessible route must be located so that a person with a disability can keep his/her personal belongings within sight
- A procedure should be in place for security personnel to utilize a hand-held metal detector wand at the accessible alternative entry route

VIII. MANEUVERING DISTANCES

Understanding maneuvering clearances required by ADA standards are critically important to ensuring people with disabilities can truly access the built environments around them. Maneuvering clearances at doors, doorways, and gates need to provide enough space for people using wheelchairs, walkers, and other mobility aids, to open and proceed through them.

- Maneuvering clearances shall extend the full width of the doorway and the required latch side or hinge side clearance.

Table 404.2.4.1 Maneuvering Clearances at Manual Swinging Doors and Gates

Type of Use		Minimum Maneuvering Clearance	
Approach Direction	Door or Gate Side	Perpendicular to Doorway	Parallel to Doorway (beyond latch side unless noted)
From front	Pull	60 inches (1525 mm)	18 inches (455 mm)
From front	Push	48 inches (1220 mm)	0 inches (0 mm) ¹
From hinge side	Pull	60 inches (1525 mm)	36 inches (915 mm)
From hinge side	Push	54 inches (1370 mm)	42 inches (1065 mm)
From latch side	Pull	42 inches (1065 mm) ²	22 inches (560 mm) ³
From latch side	Push	48 inches (1220 mm) ⁴	24 inches (610 mm)
From latch side	Push	42 inches (1065 mm) ⁴	24 inches (610 mm)

- Greater clearance is required for 180 degree turns around narrow obstructions and for wheelchair turning space.
- The minimum 36" continuous clear width of accessible routes can be reduced to 32" at points, such as doorways, for a maximum distance of 24".
- Additional clearance is required at 180 degree turns around an element that is less than 48" wide.
- The clear width must be at least 48" at the turn and 42" minimum approaching the turn (unless the clear width at the turn is 60" minimum).

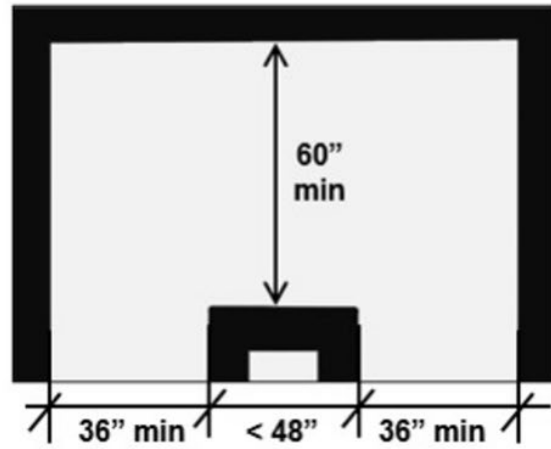
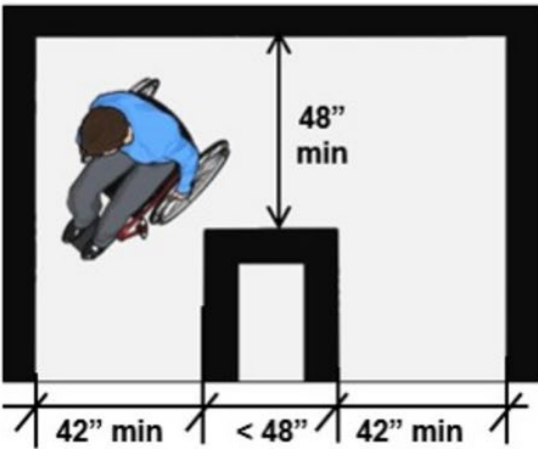

- Passing space is required every 200 feet and must be provided as a 60" by 60" minimum space or as T-shaped space where each stem is at least 48" long.

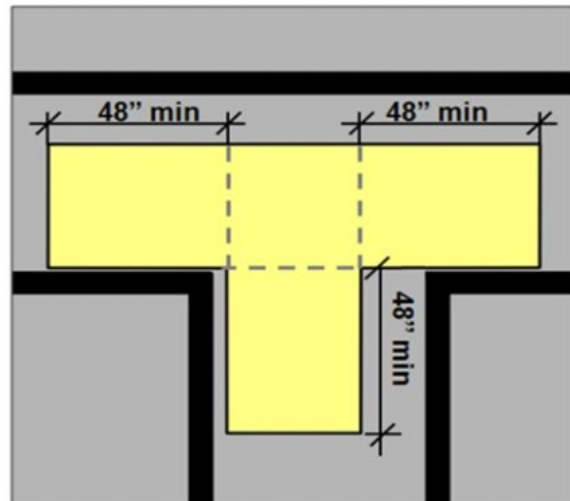
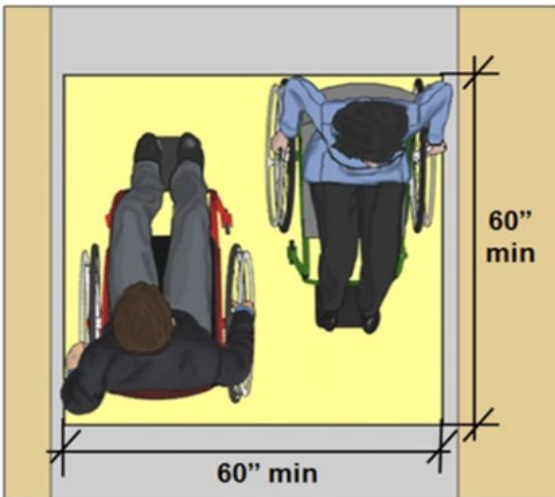

- The minimum clearance cannot be reduced by any elements, including handrails or protruding objects.
- Objects mounted on walls, partitions, columns, and other elements along circulation paths can pose hazards unless their projection is limited.
- Those with leading edges that are within cane sweep (27" high maximum) or that provide minimum headroom clearance (80" minimum) do not pose hazards and can protrude any amount.

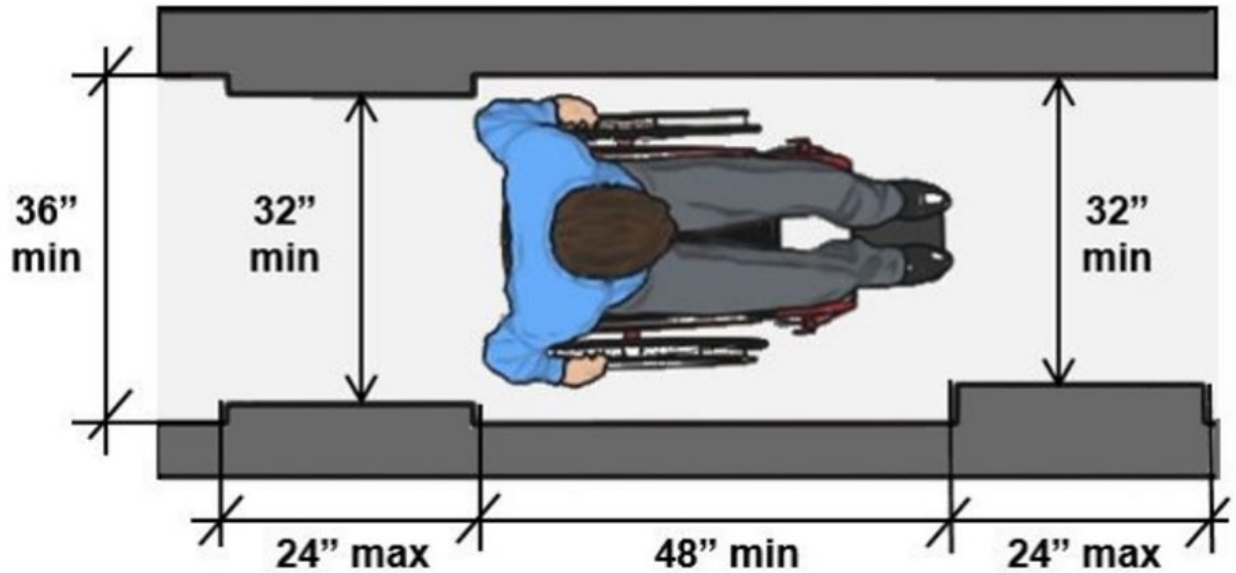

IV. THRESHOLDS

- The height of thresholds is limited to 1/2" in new construction.
- The edge must be beveled 1:2 maximum above a height of 1/4".
- A maximum height of 3/4" is permitted for existing or altered thresholds if they have a beveled edge on each side with a slope not steeper than 1:2.

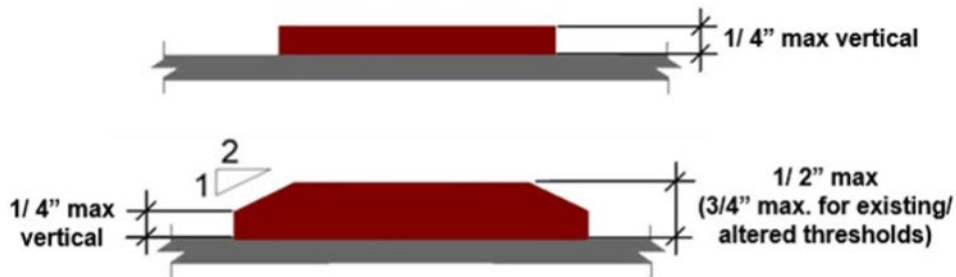

Note: vertical edge must be located below bevel, not above

- Height includes all types of doors, including sliding doors.
- Carpeting must be securely attached so that it does not shift or buckle against wheeled traffic.
- Exposed edges must have trim on the entire length of the exposed edge and be fastened to the floor to prevent curling.
- Trim must meet specifications for changes in level, including requirements for beveled edges when the height exceeds 1/4 inch.

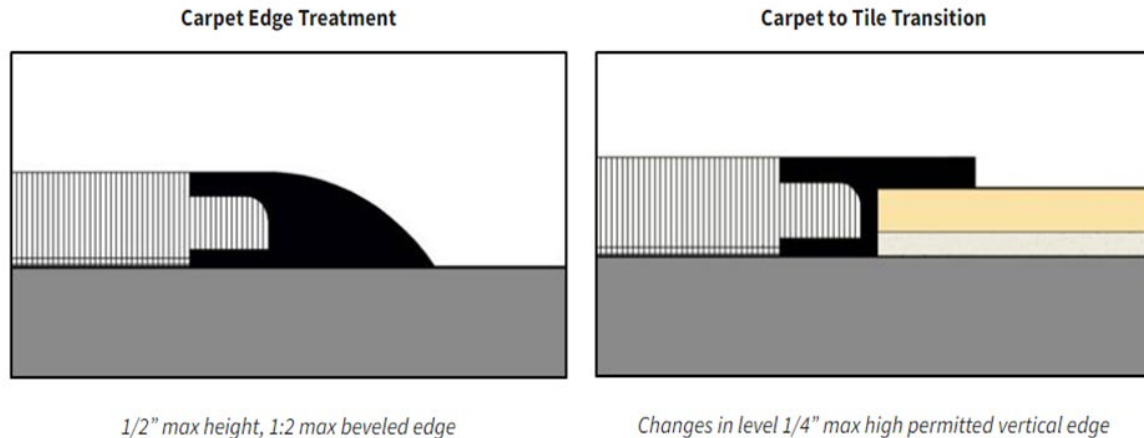

- Changes in level can be up to 1/4" without treatment or 1/2" if beveled with a slope no steeper than 1:2.
- Changes in level above a 1/2" must be treated as a ramp or curb ramp (or a walkway if a slope no steeper than 1:20 can be achieved).
- These specifications apply to all portions of accessible routes, including thresholds and carpet trim.
- Carpet:
 - The standards specify the maximum pile height (1/2" measured to the backing, cushion, or pad) and texture (level or textured loop, level cut pile, or level cut/uncut pile) and require firm backing.
 - Cushions or pads also must be firm or can be avoided to ensure greater firmness.
 - Exposed edges must have trim on the entire length of the exposed edge and be fastened to the floor to prevent curling.
 - Trim must meet specifications for changes in level, including requirements for beveled edges when the height exceeds 1/4 inch.
 - The maximum height is 1/2 inch.
- Changes in level:
 - Changes in level can be up to 1/4" without treatment or 1/2" if beveled with a slope no steeper than 1:2.
 - Changes in level above a 1/2" must be treated as a ramp or curb ramp (or a walkway if a slope no steeper than 1:20 can be achieved).
 - These specifications apply to all portions of accessible routes, including thresholds and carpet trim.

X. DOORS AND DOORWAYS

A. Doorways

Doorways are a crucial part in accessing the court buildings and important areas requiring access by a number of personnel and members of the public. When designing doorways, keep in mind the number of challenges that may affect members of the public with disabilities.

- At least one accessible door, doorway, or gate serving each accessible room, space, and entrance must comply:

- Minimum width
- Minimum opening angle

- The clear width is measured from the stop to the face of doors or gates open 90° (or to the leading edge of sliding or folding doors).

- At hinged or pivoted doors or gates in series, a separation is required that is at least 48" plus the width of doors or gates swinging into the space.

- Door clearances must provide unobstructed space for maneuvering through doorways

- Clearances must be free of protrusions the full height of the doorway

- The bottom surface of doors and gates on the push side must be smooth to a height of at least 10".

- Manual doors, doorways, and gates that are designed to be operated only

by security personnel, such as guards in a jail or prison, are exempt from requirements for hardware, closing speed, and opening force, but must meet all other requirements, including those for maneuvering clearance.

- Courthouse doors are often large and heavy. While there is no minimum force requirement for exterior doors, if the opening force at an entrance door is greater than 5 pounds, automated doors should be provided. (Automated doors or power assisted doors are required for all U.S. General Services Administration buildings under its Public Building Standards.)

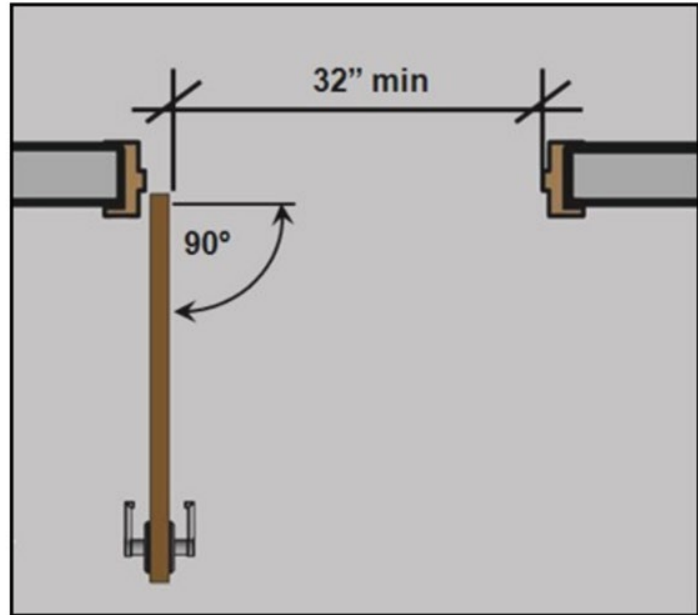

B. Door Hardware

Door and gate hardware must:

- allow one-hand operation
- not require tight grasping, pinching, or twisting of the wrist,
- be located 34" to 48" above the floor or ground,
- should require no more than 5 pounds of force,
- should not be difficult to operate/manipulate
- latches and locks with small parts that must be manipulated can be difficult to use and will not comply if pinching is necessary.
- keys and access cards that are not part of the lockset are not required to comply

C. Automatic Doors, Power Assisted Doors, and Two-Way Communications Systems

- Doors are not required to be automated, but must comply when provided.

- Clear floor space at controls must be located outside the door swing to prevent users from getting hit by the door.
- Where two-way communication systems are provided, they must include visual and audible signals to accommodate people with hearing, speech, or visual impairments.
 - Lighted signals should have labels to indicate their meaning.
 - If handsets are provided, cords must be at least 29" long.
 - This applies to all entrances equipped with such systems.

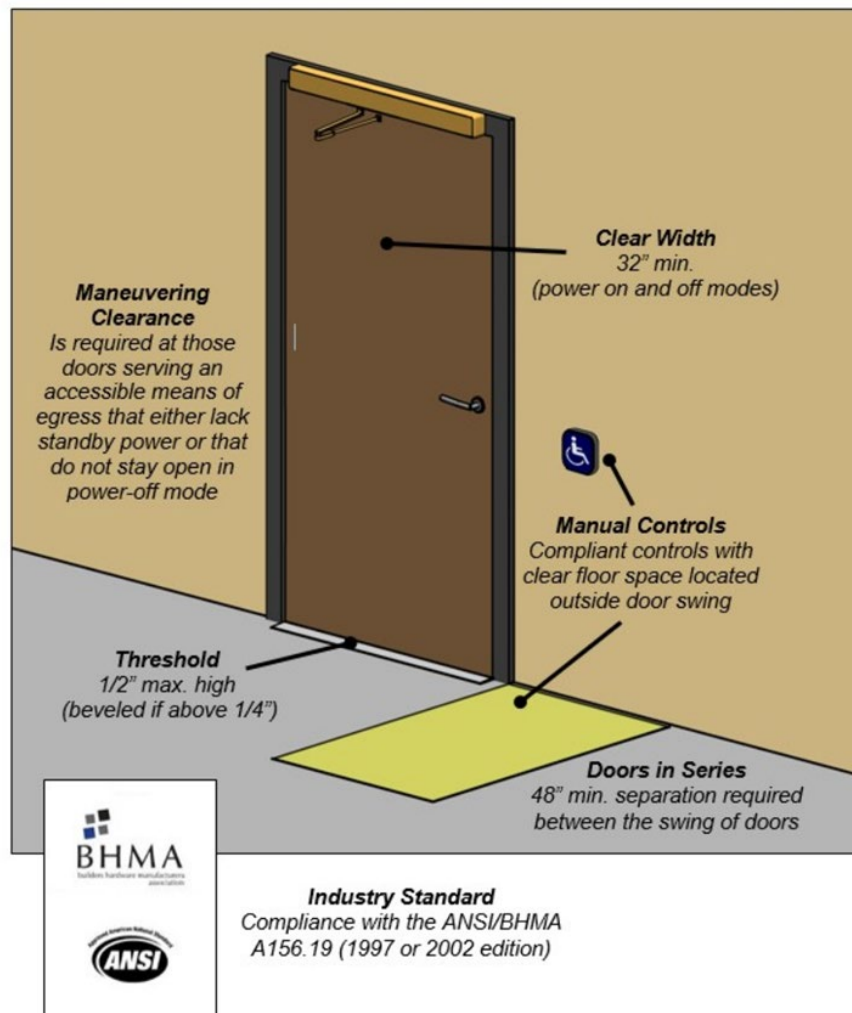

XI. CLEARANCES

- Objects located above elements that are within cane sweep can protrude 4" maximum from the leading edge of such elements provided that any required reach or clear floor space is not obstructed.

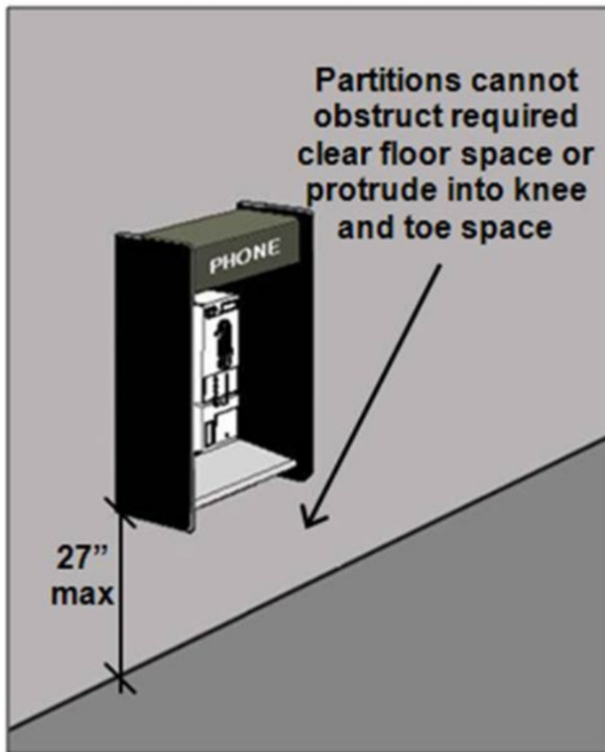
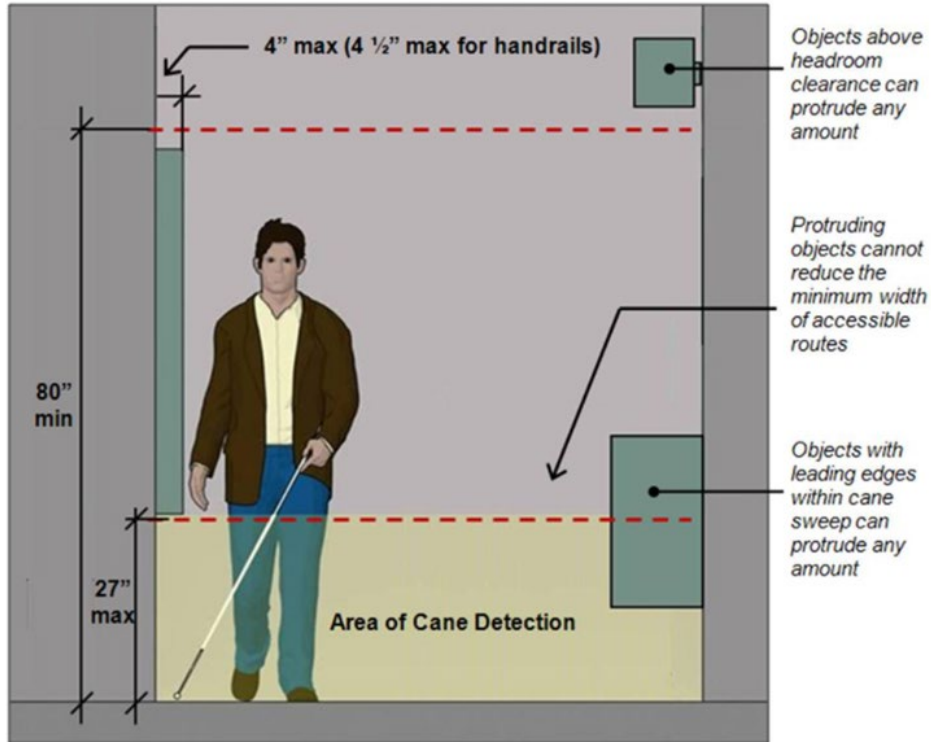

- Side partitions or panels and wing walls can also be used to make protruding objects compliant.
- The bottom edge of panels or partitions must be 27" high maximum.
- Objects can be recessed in alcoves so that they do not project more than 4" into circulation paths.
- Alcoves must be sized to accommodate required clear floor space at accessible elements.

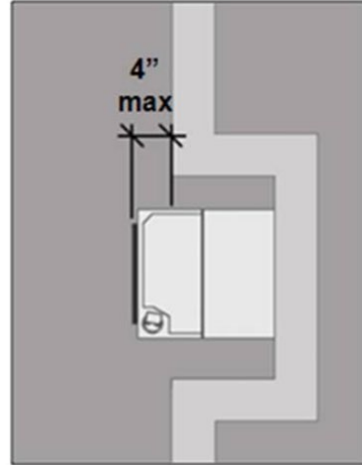

- Elements, such as wheelchair accessible drinking fountains, must provide a knee clearance of at least 27".
 - If located to provide, but not exceed this clearance (27" above the floor or ground absolute), they are not protruding objects because the leading edge will be within cane detection.
- Free-standing objects with leading edges 27" to 80" high that are mounted on posts or pylons cannot protrude more than 12" into circulation paths.
 - The 12" limit also applies to the clearance between multiple posts (excluding the sloping portions of handrails).
- Objects with leading edges 27" maximum or above 80" can protrude any amount from posts or pylons.
- Headroom clearance of at least 80" high is required along all circulation paths (except at doors and doorways where a 78" minimum clearance is permitted to accommodate door stops and closers).
- Fixed barriers, such as guardrails, are required where the vertical clearance is less than 80" such as at open stairways and along sloped or curved walls.
- Barriers must have leading edges no higher than 27" so that they are within cane sweep.
- Fixed planters, benches, and other elements can be used instead of guardrails.

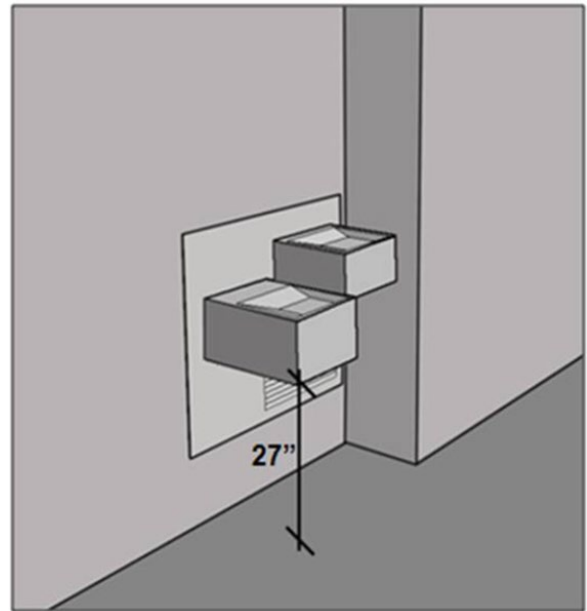

XII. STAIRWAYS AND HANDRAILS

- Exterior stairs that are part of a required means of egress must meet ADA Standards.

- Compliance is required for all stairs on required egress routes, including those consisting of a single riser.
- The Standards do not apply to stairways that are not part of a required means of egress nor to alternating tread devices and “ship’s ladders.”
- The Standards exempt aisle stairs in assembly areas and stairs in non-public areas of detention and correctional facilities.

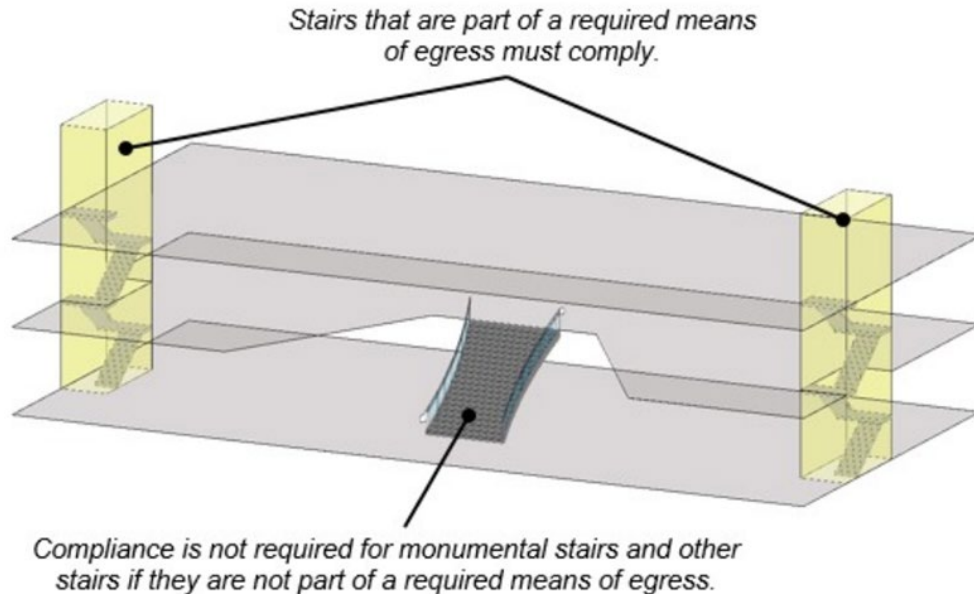

- Providing visual contrast (light-on-dark or dark-on-light) on the top and bottom steps that is approximately 2 inches wide and located either on nosings or at the leading edges of treads is helpful for people with low vision.

Treads and Risers (§504.2 and §504.3)
All steps on a flight must have uniform riser heights within a range of 4" – 7" and uniform tread depths that are 11" min. Open risers are prohibited.

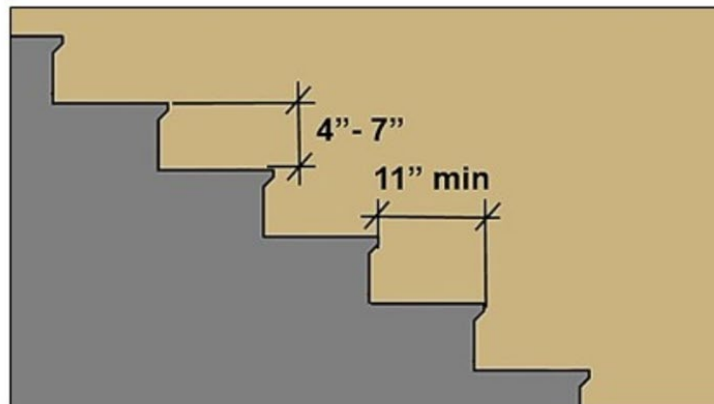

Tread Surface and Wet Conditions (§504.4 and §504.7)
Tread surfaces must comply with requirements for ground and floor surfaces (§302) and cannot have changes in level other than slopes not steeper than 1:48. Treads and landings subject to wet conditions must be designed to prevent the accumulation of water.

- Handrails are required on both sides of stairs and must be continuous within the full length of each stair flight.

- Inside handrails on switchback or dogleg stairs must be continuous.

- Handrail extensions at the top and bottom must return to walls, guards, or floors and horizontal portions must comply as protruding objects.

- The length is measured to the start of the return radius.

- Handrails at the top of stairways must extend 12 inches minimum horizontally above the landing

- Handrails at the bottom must extend beyond the last riser for a distance of at least one tread depth, unless connecting to another set of handrails.

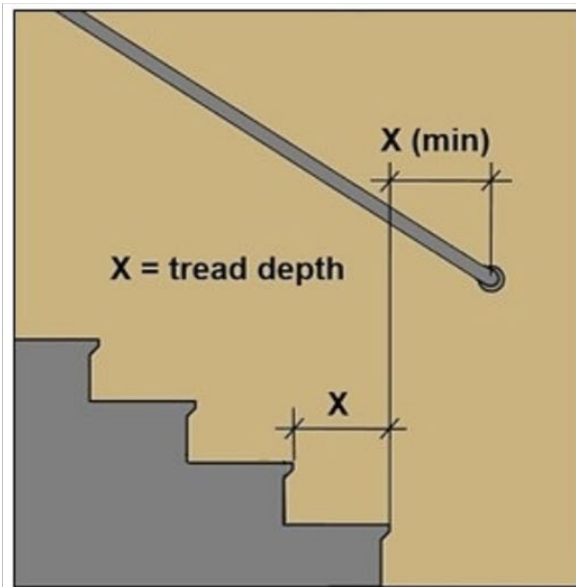
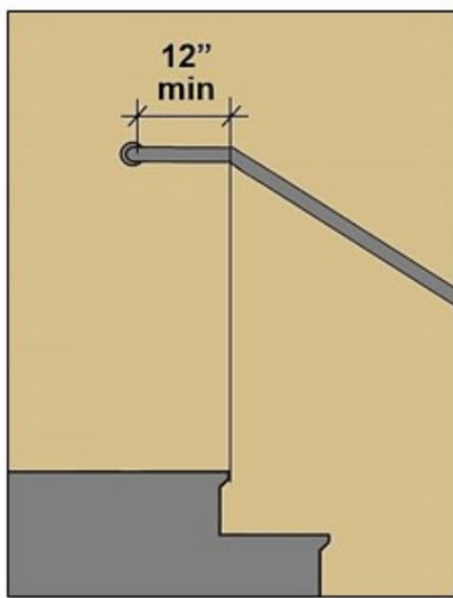
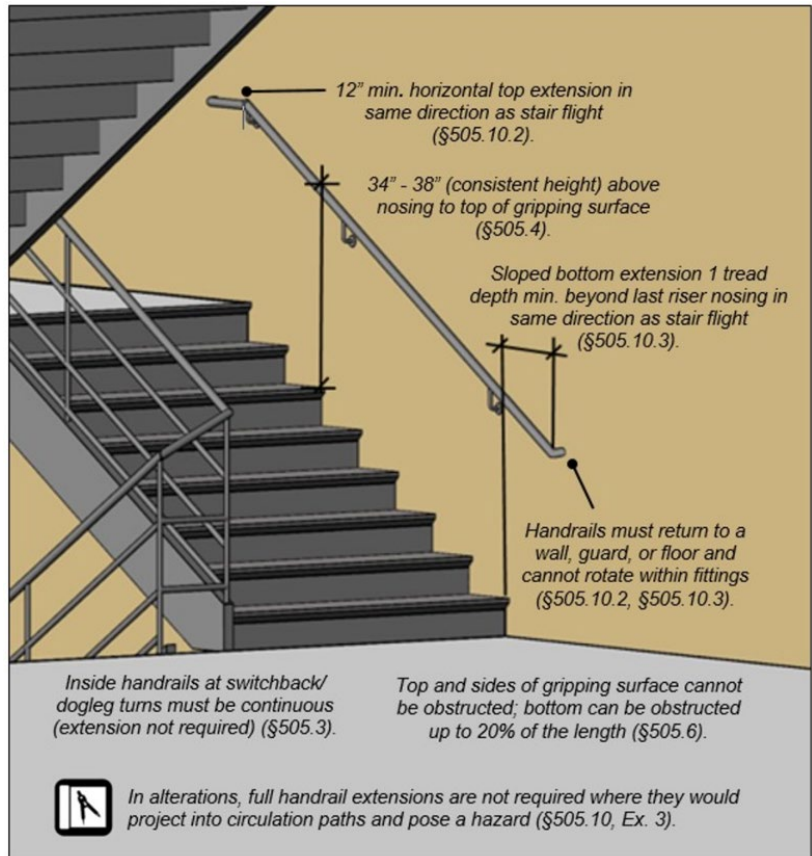

- Surface requirements and clearances facilitate a power grip along the length of handrails.

- Handrails can have circular or non-circular cross-sections, but must have rounded edges.
 - The gripping surface and adjacent surfaces must be free of abrasive or sharp elements
- Wall-mounted handrails with leading edges higher than 27" cannot protrude more than 4½" into circulation paths.
- Projecting objects above handrails can impact their usability. Keep wall surfaces above handrails free of any protrusions.
- Aisle ramps (or portions of them) adjacent to seating that are not part of a required accessible route to accessible seating or to other accessible elements do not have to comply with any ramp or handrail requirements.
- Aisle ramps that are part of a required accessible route can have handrails on at least one side or within the aisle width instead of on both sides as required for other types of ramps.
 - Handrails on assembly area ramps can be discontinuous and lack extensions to allow access to seating and to permit crossovers within aisles.

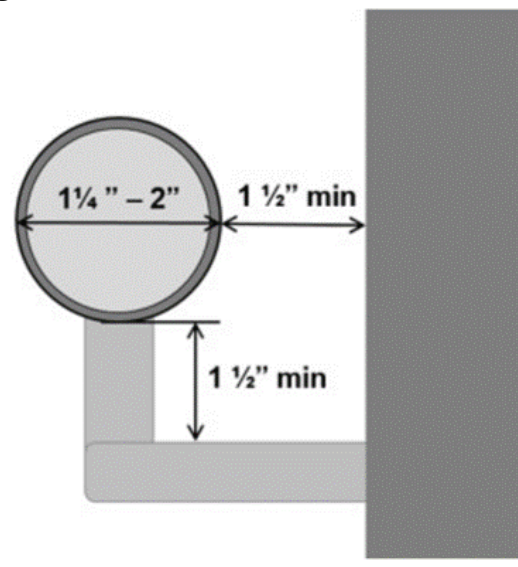

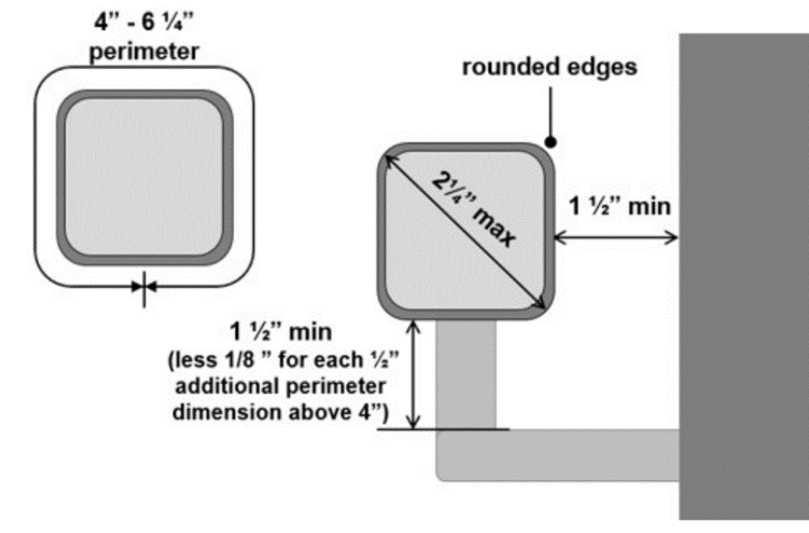

THE INTERIOR:

LOBBY WAITING AREAS

Public waiting areas should be easily accessible from the main public entrances. Seating areas should be provided, but should not obstruct traffic patterns. In addition to a lobby area near the main entrance, large hallways or special waiting rooms, with comfortable seating, in which visitors may wait and attorneys can meet with their clients, should be planned near courtrooms.

COURTROOM, ADDITIONAL ROOMS, AND ENTRY

Courtroom Entry

In new construction, the guidelines require that, at a minimum, the following entrances be accessible:

- At least **60% of public entrances** must be accessible. Public entrances are those entrances that are not a service entrance or a restricted entrance.
- **All entrances from parking garages** that provide direct pedestrian access between the garage and the building or facility.
- At least **one entrance from each tunnel or elevated walkway** that provides direct pedestrian access.
- At least **one restricted entrance**, which is an entrance that is made available for common use on a controlled basis, but not for public use, and that is not a service entrance.
- At least **one detainee entrance**. Doors operated solely by security personnel are exempt from the specific requirements for hardware, opening force, closing speed, and automation. Only doors operated solely by security personnel qualify for this exemption. Entrance doors operated sometimes by security personnel and sometimes by employees or the public must meet all requirements for accessible entrances.
- At least **one entrance to each tenancy** in the building or facility (i.e. if there are multiple buildings constituting the court facility).
- At least **one service entrance** if it is the only entrance to a tenancy.
- At inaccessible entrances, **signage is required** to direct people to the accessible entrance.

Seating:

Wheelchair seating:

- At least one wheelchair space is required in assembly areas with up to 25 seats; at least two are required in those with 26 to 50 seats.
- Locations must adjoin an accessible route and not overlap the main aisle.
- Must be at least 36 inches wide and 48 inches deep if a front approach is provided, or 60 inches deep if a side approach is provided.
- Must provide a level surface and be adjacent to a companion so that the person using a wheelchair is provided shoulder alignment with the person in the adjacent seat.
- Where armrests are provided on seats, 5% of the aisle seats must have folding or retracting armrests. If the seats are benches, end caps may remain.
- Locations can overlap the pathway between rows. However, spaces should be designed so that an individual using a wheelchair does not have to move out of the row to allow others to access the row.
- Where more than one wheelchair space is provided, wheelchair seating locations should be dispersed, so that individuals using wheelchairs have the same sight lines and variety of choices as other spectators.
- Wheelchair spaces should be placed so that they are easy to maneuver into and do not obstruct the main aisle or access to seating for other spectators.

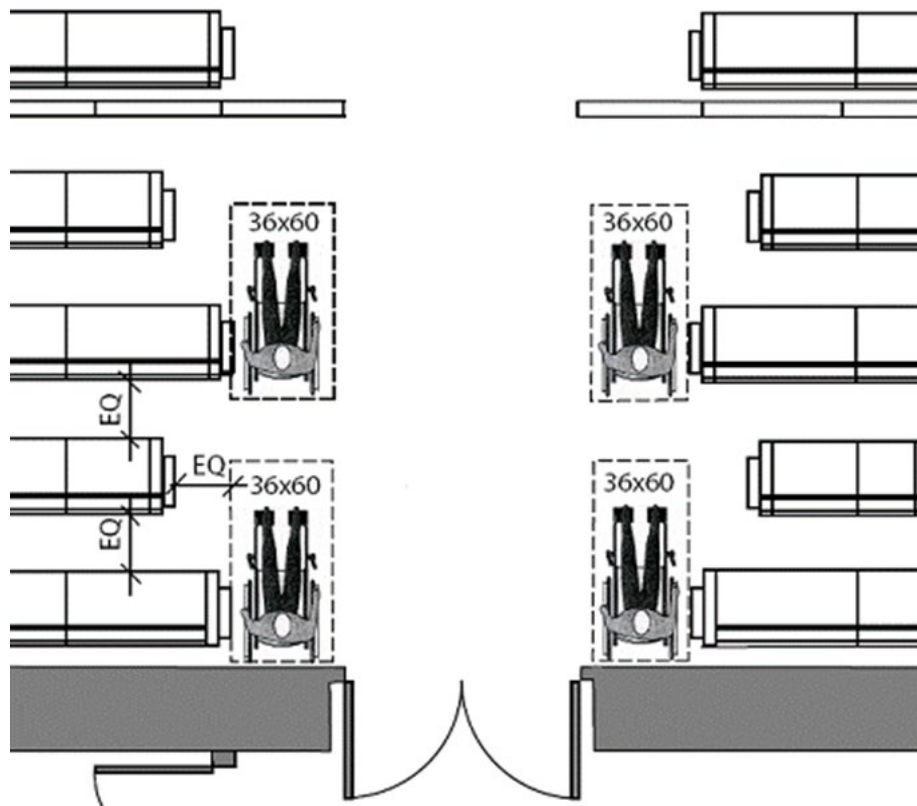

Rail (Bar)

Courtrooms are often designed with a rail bar, or partition that separates the judges, attorneys, jury, and parties to the action from the general public.

- If a rail is used, the gate or opening in the rail must be a minimum of 32 inches clear width and meet maneuvering clearances.
- Gates, if used, must have compliant hardware and meet specifications for opening force (5 pounds of force maximum), closing speed, and surfacing.
- Ideally, a gate would not be used as part of the rail bar; however, if it is, then it should extend to the floor so a person using a wheelchair can push the gate open with footrests.

Jury Box

The jury box should include one accessible wheelchair space, located within the defined area of the jury box; access to this wheelchair space shall coincide with the circulation path provided for all persons using the jury box. If this wheelchair space is located on a tier within the jury box, a permanent ramp or lift, located on the circulation path used by all jurors, may be used to access this space.

Each jury box must have, within its defined area:

- Wheelchair space that is connected by an accessible route. In general, clear floor space for wheelchairs must be at least 30 inches wide and at least 48 inches deep.
- Additional maneuvering room is required where the space is confined on three sides by fixed elements such as walls, elevations, railings, or seating.
- Space entered from the front or back that is confined on[5] both sides more than 2 feet horizontally must be at least 36 inches wide. Space entered from the side that is confined at the front and back more than 15 inches horizontally must be at least 60 inches deep to permit adequate maneuvering space for a parallel approach.
- The design needs to provide sufficient clear floor space for the person using a wheelchair to get into the space provided,
- It may be more efficient to leave the first tier of the jury box at floor level, particularly if a three-tier box is to be used. Audio jacks for earphones or other assistive listening devices should be available at several positions for use by the hearing impaired.
- Gates into jury boxes should be avoided.
- Removable seats in wheelchair seating spaces in jury boxes should be readily removable, without requiring tools.
- Jury boxes should be designed for shoulder alignment so a juror with a disability is fully integrated with other jurors.
- See photo on the next page for reference.

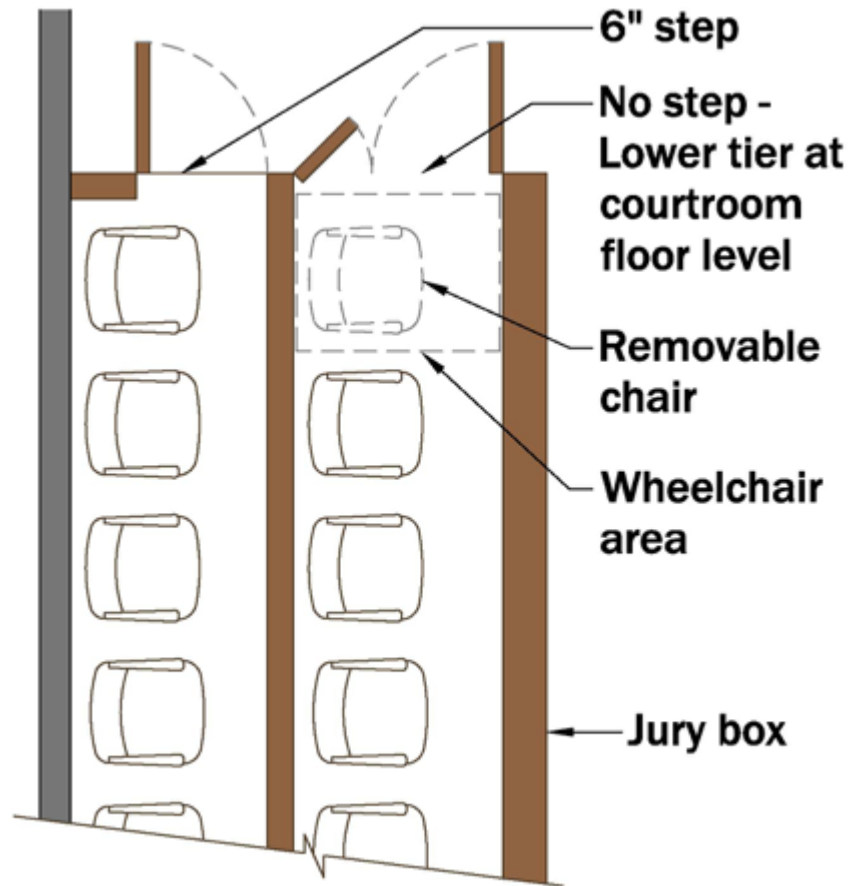

Witness Stand

- The witness stand should be designed such that it is at ground level or a ramp should be provided for ease of access. The area inside of the stand should provide enough space for maneuvering should it be required.

Judge's Bench

- Access to the Bench should be similar to the witness stand. Access to the front of the bench should be at a level that wheelchair users may access the judge without undue burden or shame. A Judge's bench might serve better at ground level than elevated.

Clerk's and Bailiff's Stations

- Clerks and Bailiff's stations should be at ground level and easily approachable by anyone. Maneuvering areas behind the desks should be adequate for mobility issues.

Court Reporter Area

- A relatively easy solution to making the court reporter station wheelchair accessible is to locate it at floor level adjacent to the witness stand.

Furnishings

- Counsel Tables
 - The attorney tables should be accessible with adequate access to, and maneuvering room behind a table.

- Counsel tables should also be fitted with a visually compatible section that accommodates the arm height of a wheelchair.
- Lecterns
 - If a lectern is required by the court, the court should provide either an adjustable or a fixed lectern with the counter or desk height between 28 inches and 30 inches above the floor and knee space at least 27 inches high, 30 inches wide, and 19 inches deep. A clear floor space of 30 by 49 inches shall be provided at each accessible lectern.
 - A movable lectern that is designed to be wheelchair accessible can be provided within the court facility and moved to a particular courtroom when needed. Such a lectern can be purchased commercially.
- Audio/Visual
 - Minimum Requirements:
Audio / visual (AV) carts should be designed so that all user controls are within the reach range. All controls should be placed within accessible reach ranges, be operable with one hand, and not require tight grasping, pinching, or twisting of the wrist. If there is a work surface, it should be 28 inches minimum and 34 inches maximum above the floor.
 - A portable assistive listening system may be used in those courtrooms that lack a permanent system. Receivers for this system should be provided for a minimum of 4 percent of the room occupant load, but there should be at least two receivers. The system should accommodate the public, as well as attorneys, jurors, judges, witnesses, court clerks, and court reporters. Two-track systems are now available that allow interpreters to transmit translations of court proceedings with the same system.
 - Consideration should be given to accommodate other assistive systems and equipment, including real-time transcription.
 - Microphones, if provided at the judge's bench, witness stand, counsel tables, and other positions within the courtroom, should be adjustable for minor movement within each space. A gooseneck microphone will suffice for this.

Judges' Chambers

- All Judges Chambers should be easily accessible by all members of the public that may have to access the offices.
 - The route to the chambers should be easily accessible to all.
 - The doorway leading into the chamber should be in conformity with the doorway requirements listed on page
 - Inside the chamber enough space should be provided such that a justice with mobility concerns or anyone else can easily maneuver inside.

Jury Deliberation Suite

- All jury deliberation rooms should be fully accessible to persons with disabilities and accommodate wheelchairs.
 - Access to and from the courtroom should be barrier free.
 - Deliberation areas shall accommodate at least one accessible wheelchair space at built-in seating and tables.
 - Other requirements are identical to those required for the jury assembly room. Dedicated refreshment areas, kitchenettes, and toilets must be accessible.

- Fifty percent of each type of jury deliberation room provided shall have a permanently installed assistive listening system. A portable assistive listening system may be used in the remaining deliberation rooms.
- It may be easier and more efficient to make every deliberation room fully accessible rather than to rely on moving equipment to and from different rooms, and it may not be feasible to have jurors use alternative jury rooms to accommodate handicapped jurors.
- Consideration should be given to other assistive systems, such as real-time translation, note takers, and interpreters, in developing policies and architectural design.

Holding Cells

- Doorways accessing cells should be wide enough to accommodate mobility aids and wheelchairs. The inside of the cell should have enough space to turn and maneuver as needed. The door sealing the cell does not have to be accessible because it is a controlled access pathway.

Restrooms

- At a minimum, restrooms should have one toilet with necessary railing and at proper height. The hand washing facilities should have clearance below to allow for access by all parties. In larger bathrooms, a minimum of one stall should be designed for people with disabilities, as well as a sink facility. Access to the restroom should be clear and free of obstructions, and signage marking the location of the restroom should accommodate those with sight disabilities. The doorway accessing the restroom should not be difficult to open

Signage: There must be ADA compliant bathroom signs that feature raised Braille characters as well as raised pictorial symbols

Grab bars: Grab bars must be 36 inches at the rear wall and 42 inches on a side wall. They must also have at least an inch and a half clearance from all directions. At a public toilet compartment, a grab bar must be attached a foot from the rear wall while a separate grab bar cannot be mounted more than half a foot from the side wall. They should also be conveniently placed near the location of toilet paper and a hand dryer.

Toilet: Overall, an ADA accessible toilet must be at least 60 inches wide;

- The flush lever is located on the open side.

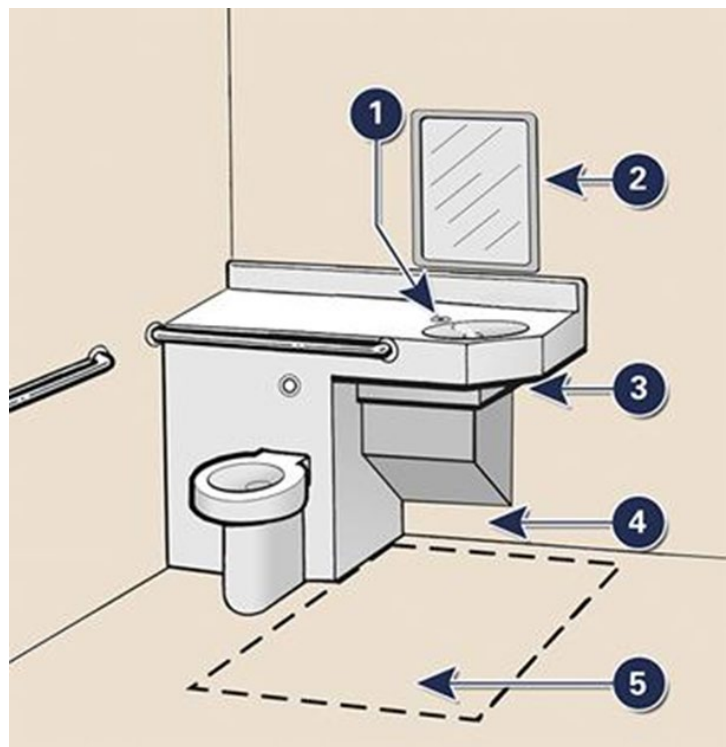

- The center of the toilet must be between 16 to 18 inches of space from the side wall and the toilet seat must be at least 17 to 19 inches above the floor.

Clear floor space: Clear floor space at toilets (60 inches wide by 56 inches deep, minimum) permits space for side transfers. Lavatories are not permitted to overlap this space.

Lavatories/Sinks:

- Where sinks are provided in accessible rooms or spaces, at least 5%, but no less than one, of each type must comply.
- Other types of sinks used only by employees to perform work are not required to comply, although compliance is advisable.
- Clear floor space at lavatories and most sinks must provide a forward approach and include knee and toe space clearance.
- No element, including towel dispensers, hand dryers, etc., can overlap the clear floor space outside the designated knee and toe space.
- Faucet controls, soap dispensers, and other elements that require manual operation must be usable with one hand and not require tight grasping, pinching, or twisting of the wrist

Sink: An ADA compliant sink must be at least 34 inches above the floor. To give ample room for someone using a wheelchair, there should be a knee clearance of 27 by 30 inches wide and 11 to 25 inches deep.

Faucets: Faucet handles or controls need to be usable with one loosely closed fist, because some people with disabilities can use only one hand and cannot grasp or twist faucets. Lever-operated, push-type mechanisms, and U-shaped handles are acceptable designs.

Mirrors: If provided, mirrors need to be mounted with the bottom edge of the reflecting surface no higher than 40 inches above the floor.

Lavatory Knee Clearance: To allow persons who use wheelchairs to pull under the lavatory and to use the faucet hardware, the following features need to be provided – the top of the bowl mounted no higher than 34 inches above the floor, a 27-inch-high clearance for knee space extending at least 8 inches from the front of the lavatory, and a 9-inch-high toe space extending not more than 6 inches from the back wall.

Protection from Sharp Edges: To protect against sharp edges or hot surfaces, pipes need to be covered or otherwise configured to protect against contact.

Floor Space: Clear floor space is needed for a forward approach to the lavatory.

Drinking Fountains

- In the event a single water fountain exists, it should have clearance below and around the unit and should be at a height accessible to all members of the public. If there are multiple fountains, the second unit may be at a high height, but must meet clearance requirements outlined above.

Accessible Routes

- An accessible route between stories is required in multi-story government facilities subject to title II of the ADA except those with no more than two stories where the inaccessible story above (or below) the entry level has no public use space and an occupant load of five maximum.

III. ACCESS TO EXITS

An exit access is a route or path that leads (provides access) to an accessible exit. The IBC requires at least two means of egress from all spaces and buildings with few exceptions. Some spaces and buildings are allowed to have one means of egress if the travel distance to an exit is short and the occupant load is low. Occupant load is defined in the 2010 ADA Standards as “the number of persons for which the means of egress of a building or portion of a building is designed.” For example, a business occupancy with no more than 30 occupant load and a maximum exit access travel distance of 75 feet is permitted to have a single means of egress. More than two means of egress are required where the occupant load is 500 or more (at least 3) and 1,000 or more (at least 4).

The IBC (2003) permits one accessible means of egress from:

- wheelchair seating in assembly areas with sloped floors where the common path of travel meets aisle requirements for assembly areas and,
- mezzanines served by an enclosed exit stairway or elevator equipped with standby power

The IBC requirements for accessible means of egress apply to new construction; accessible means of egress are not required to be added in alterations to existing facilities.

IV. INTERIOR AREA OF REFUGE

An interior area of refuge is usually found beyond the interior manual egress door discussed above and at a landing of a stair system. Areas of refuge are fire-resistance rated and smoke protected areas where those unable to use stairs can register a call for evacuation assistance and await instructions or assistance. Horizontal exits can substitute for areas of refuge.

For buildings not equipped with a supervised fire suppression sprinkler system, area(s) of refuge should be provided. These areas of refuge must provide direct access to exit stairways and can be located adjacent to stairway enclosures or on stair landings outside the minimum exit width. The graphic below shows where the interior areas of refuge can be located.

V. ACCESS TO RAISED ELEMENTS IN COURTROOMS AND COURTHOUSE

Minimum requirements for ramps:

- Ramps must be permanent, not pull-out, flip-down or removable.
- Ramps must provide a minimum clear width of 36 inches between handrails.
- Landings where ramps change directions must have a minimum dimension of 60 inches x 60 inches.
- If a door is located at the top or bottom of a ramp, the landing must be large enough for adequate maneuvering clearances at the door. If the door swings back over the landing, there must be adequate landing space to back up to clear the door swing.
- Raised platforms accessed by ramps must have a turning space to allow an individual to turn around to go down the ramp.

- Ramps must have a maximum slope of 1:12.
- Ramp runs and landings with drop-offs must have edge protection, such as a curb, barrier, or extended surface as specified in the guidelines.
- Ramps with a rise of greater than 6 inches need handrails. Handrails must be located along both sides of a ramp at a height above the ramp surface of 34 inches to 38 inches measured to the top of the handrail.
- Most model building codes require a guard where there is a drop-off of more than 30 inches. If the ramp or landing has such a drop-off along any side, it must also have a guard at that location in addition to handrails. The minimum height of a guard is 42 inches with maximum openings of 4 inches.

VI. DETERMINING ACCOMODATIONS FOR JUDICIAL ACTIVITIES

There are no specific statutes or rules governing the Mississippi state courts' process for responding to requests for reasonable modifications, other auxiliary aids, or other modifications relating to judicial activities. The public should be informed that requests are to be made to the ADA Coordinator for the specific court or jurisdiction. Notice of the designated individual and the process should be posted online, at the courthouse, and other locations regarding judicial services. This information should also be included in documents produced by the court for the public or parties, such as jury notices, notices of hearings, and information about mediation.

For issues that may occur regularly and do not relate to individualized needs, a court should ensure that policies in certain areas are in place in advance, without the need for a request. Topics would include service animal access (including circumstances under which a service animal may be excluded), security procedures, and mobility devices. Other on-the-spot or relatively simple accommodations may be made in the regular course of business, as a matter of customer service, without the need for a procedure. For example, staff should be prepared to assist individuals with manual dexterity disabilities or vision disabilities in filling out a form (while maintaining privacy and confidentiality).

VII. CONSIDERATIONS FOR COURHOUSE EMPLOYEES AND STAFF WITH DISABILITIES

Courtrooms must be accessible to judges and staff, attorneys, and the public, as well as detainees. Staff workstations, including the judge's bench, clerks' workstations, court reporter, and bailiff, must be accessible to the staff members who work and function in the building/area. Reasonable accommodations should be made. If accessibility is not currently required, the space should be adaptable for accessibility at a later date.

VIII. HISTORIC PRESERVATION

Many historic courthouses represent the importance of justice in the country's rich history. Courts face significant challenges in making historic courthouses accessible for people with disabilities while preserving the historic character of these structures. The ADA does not exempt historically significant facilities from coverage by the new construction and alteration standards. If any alterations are made to a historic courthouse for example, installing or modifying a restroom or drinking fountain, a court must follow the accessibility standards to the maximum extent feasible. If following

these standards would result in damage to the historic significance of the courthouse, alternative standards that provide "a minimal level of access" may be used.

The ADA provides that public entities are not required to make structural changes to historic facilities if doing so would "threaten or destroy" the historical significance of the property. This provision applies only to properties that are listed or eligible for listing in the National Register of Historic Places or properties designated as historic under state or local law. Courts should consult their local historic advisory board or the State Historic Preservation Division regarding such modifications.

Members of the community, including people with disabilities, should be invited to participate in whatever process the court uses to make decisions regarding modifications. Under the program access requirement, if court services cannot be offered to people with disabilities in historically significant structures, then the programs or services conducted in the facility must be offered in an alternative accessible manner or location when needed. For example, a rural county court that holds hearings in an inaccessible county courthouse may move proceedings to an accessible courtroom in a city-owned building.

IX. SERVICE ANIMALS

- A service animal is a dog that is individually trained to do work or perform tasks for a person with a disability.
- Beginning on March 15, 2011, only dogs are recognized as service animals under titles II and III of the ADA, but Mississippi ADA regulations have a separate provision about miniature horses that have been individually trained to do work or perform tasks for people with disabilities.
 - In addition to the requirements for canines, a facility may deny a miniature horse if the facility cannot accommodate the miniature horse's type, size, and weight
- Under the ADA, State and local governments generally must allow service animals to accompany people with disabilities in all areas of the facility where the public is allowed to go.
- A service animal must be under the control of its handler. Under the ADA, service animals must be harnessed, leashed, or tethered, unless the individual's disability prevents using these devices or these devices interfere with the service animal's safe, effective performance of tasks.
- When it is not obvious what service an animal provides, only limited inquiries are allowed. Staff may ask two questions:
 - (1) is the dog a service animal required because of a disability, and
 - (2) what work or task has the dog been trained to perform.
- Allergies and fear of dogs are not valid reasons for denying access or refusing service to people using service animals.
- A person with a disability cannot be asked to remove his service animal from the premises unless:
 - (1) the dog is out of control and the handler does not take effective action to control it or
 - (2) the dog is not housebroken.

- Staff are not required to provide care for or supervision of a service animal.

X. ACCOMODATIONS FOR PEOPLE WITH LOW VISION OR BLINDNESS

- People who have vision, hearing, or speech disabilities (“communication disabilities”) use different ways to communicate.
 - For example, people who are blind may give and receive information audibly rather than in writing and people who are deaf may give and receive information through writing or sign language rather than through speech.
- The ADA requires that title II entities (State and local governments) communicate effectively with people who have communication disabilities.
- For people who are blind, have vision loss, or are deaf-blind, this includes providing a qualified reader; information in large print, Braille, or electronically for use with a computer screen-reading program; or an audio recording of printed information.
 - A “qualified” reader means someone who is able to read effectively, accurately, and impartially, using any necessary specialized vocabulary.
- In addition, aids and services include a wide variety of technologies including
 - assistive listening systems and devices;
 - screen reader software and optical readers;
 - video description and secondary auditory programming (SAP) devices that pick up video-described audio feeds for television programs;
 - accessibility features in electronic documents and other electronic and information technology that is accessible (either independently or through assistive technology such as screen readers).
- Many deaf-blind individuals use support service providers (SSPs) to assist them in accessing the world around them.
 - SSPs are not “aids and services” under the ADA.
 - However, they provide mobility, orientation, and informal communication services for deaf-blind individuals and are a critically important link enabling them to independently access the community at large.
- Covered entities must provide aids and services when needed to communicate effectively with people who have communication disabilities.
- The key to deciding what aid or service is needed to communicate effectively is to consider the nature, length, complexity, and context of the communication as well as the person’s normal method(s) of communication.
 - For example: in a law firm, providing an accessible electronic copy of a legal document that is being drafted for a client who is blind allows the client to read the draft at home using a computer screen-reading program.
- In many situations, covered entities communicate with someone other than the person who is receiving their goods or services.
 - The term “companion” includes any family member, friend, or associate of a person seeking or receiving an entity’s goods or services who is an appropriate person with whom the entity should communicate.

XI. SIGN LANGUAGE INTERPRETERS

- People who have vision, hearing, or speech disabilities (“communication disabilities”) use different ways to communicate.

- The ADA requires that Title II entities (State and local governments) communicate effectively with people who have communication disabilities.
- For people who are deaf, have hearing loss, or are deaf-blind, this includes providing a qualified note taker; a qualified sign language interpreter, oral interpreter, cued-speech interpreter, or tactile interpreter; real-time captioning; written materials; or a printed script of a stock speech (such as given on a museum or historic house tour).
 - A “qualified” interpreter means someone who is able to interpret effectively, accurately, and impartially, both receptively (i.e., understanding what the person with the disability is saying) and expressively (i.e., having the skill needed to convey information back to that person) using any necessary specialized vocabulary
- Real-time captioning (also known as computer-assisted real-time transcription, or CART) is a service similar to court reporting in which a transcriber types what is being said at a meeting or event into a computer that projects the words onto a screen. This service, which can be provided on-site or remotely, is particularly useful for people who are deaf or have hearing loss but do not use sign language.
- In an emergency involving an imminent threat to the safety or welfare of an individual or the public, an adult or minor child accompanying a person who uses sign language may be relied upon to interpret or facilitate communication only when a qualified interpreter is not available.
- In situations **not** involving an imminent threat, an adult accompanying someone who uses sign language may be relied upon to interpret or facilitate communication when a) the individual requests this, b) the accompanying adult agrees, and c) reliance on the accompanying adult is appropriate under the circumstances. This exception does **not** apply to minor children.
 - Even under this exception, covered entities may **not** rely on an accompanying adult to interpret when there is reason to doubt the person’s impartiality or effectiveness. For example:
 - It would be inappropriate to rely on a companion to interpret who feels conflicted about communicating bad news to the person or has a personal stake in the outcome of a situation.
 - When responding to a call alleging spousal abuse, police should never rely on one spouse to interpret for the other spouse.

XII. ELECTION DAY ACCESSIBILITY

- While access is crucial every day, it is of the utmost importance to ensure accessibility measures are in place on Election Day so that people with disabilities can exercise their right to vote privately, independently, and without barriers.
- Temporary measures should be put in place to ensure the route to vote is accessible. This might include temporary ramps, railing, and signage.
- Poll workers should be acquainted with best practices for assisting voters with disabilities. They especially should know the following:
 - Voters with disabilities have the right to have a person of their choosing (with the exception of their employer, an agent of their employer or their employment union) help them cast their vote.

- Voters with disabilities are entitled to vote from their vehicle; polls must have a worker available to ascertain and facilitate this need.

XIII. WEBSITE ACCESSIBILITY

Increasingly, electronic and information technology is the medium for the exchange of information. More and more state and local governments, including court systems, are using the internet to inform and interact with the public. Courts use the internet to provide court information, publish opinions, rules, and case documents, accept filings, register for jury service, and more.

Many people with disabilities use assistive technology to enable them to use computers and access the internet. For example, people who are blind and cannot see computer monitors may use screen readers - devices that speak the text that would normally appear on a monitor, and keyboard controls instead of a mouse. Designers may not realize how simple features built into a web page will assist someone who, for instance, cannot see a computer monitor or use a mouse. Implementing accessibility features generally is not difficult and will seldom change the layout or appearance of web pages. An example of a barrier is a photograph of a courthouse on a court's website with no text identifying it. Because screen readers cannot interpret images unless there is text associated with it, a blind person would have no way of knowing what the image is. Simply adding a line of hidden computer code, often referred to as alt-text, to label the photograph "Photograph of County Courthouse," will allow the user who is blind to interact with the page. Similarly, a video with sound will not be understandable to a person who is deaf, without captions. Without an option for large font and high contrast, some people with low vision cannot use a website.

The Department of Justice has long made it clear that the websites of public entities, such as courts, are generally required to be accessible for people who use assistive technology.

GLOSSARY

Access Aisle: An accessible pedestrian space between elements, such as parking spaces, seating, and desks that provides clearances appropriate for use of the elements.

Accessible: Describes a site, building, facility, or portion thereof that complies with these guidelines.

Accessible Route: A continuous unobstructed path connecting all accessible elements and spaces of a building or facility. Interior accessible routes may include corridors, floors, ramps, elevators, lifts, and clear floor space at fixtures. Exterior accessible routes may include parking access aisles, curb ramps, crosswalks at vehicular ways, walks, ramps, and lifts.

Accessible Space: Space that complies with the guidelines.

Adaptability: The ability of certain building spaces and elements, such as kitchen counters, sinks, and grab bars, to be added or altered so as to accommodate the needs of individuals with or without disabilities or to accommodate the needs of persons with different types or degrees of disability.

Alteration: An alteration is a change to a building or facility made by, on behalf of, or for the use of a public accommodation or commercial facility, that affects or could affect the usability of the building or facility or part thereof. Alterations include, but are not limited to, remodeling, renovation, rehabilitation, reconstruction, historic restoration, changes or rearrangement of the structural parts or elements, and changes or rearrangement in the plan configuration of walls and full-height partitions. Normal maintenance, reroofing, painting or wallpapering, or changes to mechanical and electrical systems are not alterations unless they affect the usability of the building or facility.

Area of Rescue Assistance: An area, which has direct access to an exit, where people who are unable to use stairs may remain temporarily in safety to await further instructions or assistance during emergency evacuation.

Assembly Area: A room or space accommodating a group of individuals for recreational, educational, political, social, or amusement purposes, or for the consumption of food and drink.

Automatic Door: A door equipped with a power-operated mechanism and controls that open and close the door automatically upon receipt of a momentary actuating signal. The switch that begins the automatic cycle may be a photoelectric device, floor mat, or manual switch (see power-assisted door).

Circulation Path: An exterior or interior way of passage from one place to another for pedestrians, including, but not limited to, walks, hallways, courtyards, stairways, and stair landings.

Clear Floor Space: The minimum unobstructed floor or ground space required to accommodate a single, stationary wheelchair and occupant.

Common Use: Refers to those interior and exterior rooms, spaces, or elements that are made available for the use of a restricted group of people (for example, occupants of a homeless shelter, the occupants of an office building, or the guests of such occupants).

Cross Slope: The slope that is perpendicular to the direction of travel (see running slope).

Curb Ramp: A short ramp cutting through a curb or built up to it. (DRMS Note: You may also see or hear this referenced as a “curb cut”)

Detectable Warning: A standardized surface feature built in or applied to walking surfaces or other elements to warn visually impaired people of hazards on a circulation path.

Egress, Means of: A continuous and unobstructed way of exit travel from any point in a building or facility to a public way. A means of egress comprises vertical and horizontal travel and may include intervening room spaces, doorways, hallways, corridors, passageways, balconies, ramps, stairs, enclosures, lobbies, horizontal exits, courts and yards. An accessible means of egress is one that complies with these guidelines and does not include stairs, steps, or escalators. Areas of rescue assistance or evacuation elevators may be included as part of accessible means of egress.

Element: An architectural or mechanical component of a building, facility, space, or site, e.g., telephone, curb ramp, door, drinking fountain, seating, or water closet.

Entrance. Any access point to a building or portion of a building or facility used for the purpose of entering. An entrance includes the approach walk, the vertical access leading to the entrance platform, the entrance platform itself, vestibules if provided, the entry door(s) or gate(s), and the hardware of the entry door(s) or gate(s).

Power-assisted Door: A door used for human passage with a mechanism that helps to open the door, or relieves the opening resistance of a door, upon the activation of a switch or a continued force applied to the door itself.

Public Use: Describes interior or exterior rooms or spaces that are made available to the general public. Public use may be provided at a building or facility that is privately or publicly owned.

Ramp: A walking surface which has a running slope greater than 1:20.

Running Slope: The slope that is parallel to the direction of travel (see cross slope).

Service Entrance: An entrance intended primarily for delivery of goods or services.

Signage: Displayed verbal, symbolic, tactile, and pictorial information.

Site Improvement: Landscaping, paving for pedestrian and vehicular ways, outdoor lighting, recreational facilities, and the like, added to a site.

Space: A definable area, e.g., room, toilet room, hall, assembly area, entrance, storage room, alcove, courtyard, or lobby.

Structural Frame: The structural frame shall be considered to be the columns and the girders, beams, trusses and spandrels having direct connections to the columns and all other members which are essential to the stability of the building as a whole.

Tactile: Describes an object that can be perceived using the sense of touch.

Text Telephone: Machinery or equipment that employs interactive graphic (i.e., typed) communications through the transmission of coded signals across the standard telephone network. Text telephones can include, for example, devices known as TDD's (telecommunication display devices or telecommunication devices for deaf persons) or computers.

Vehicular Way: A route intended for vehicular traffic, such as a street, driveway, or parking lot.

Walk: An exterior pathway with a prepared surface intended for pedestrian use, including general pedestrian areas such as plazas and courts.

ACCESSIBILITY LAWS, REGULATIONS, AND STANDARDS

There are several Federal laws that require access to the built environment, including courthouses, through adopted accessibility standards. These laws include the Architectural Barriers Act (ABA), the Rehabilitation Act, and the Americans with Disabilities Act (ADA).

ADA and ABA Accessibility Guidelines

Standards used to enforce the design requirements of the ADA and ABA are based on accessibility guidelines developed by the Access Board. The Board's guidelines specify how accessibility is to be achieved in new construction and alterations and provide design criteria for various building elements and spaces, including entrances, ramps, parking, restrooms, and telephones, among others. The guidelines address a wide range of facilities covered by the ADA and the ABA, including places of public accommodation, commercial facilities, and government facilities.

In 2004, the Board completed a comprehensive review and update of its facility guidelines so that they continue to meet the needs of people with disabilities and keep pace with technological innovations. The Board updated the ADA guidelines and the ABA guidelines jointly so that a consistent level of accessibility is specified under both laws. The ADA and ABA Accessibility Guidelines contain new and revised provisions that enhance coverage of accessibility and facilitate compliance. As part of this update, The Board harmonized the guidelines with model building codes and industry standards.

The updated guidelines provide a new baseline for the enforceable standards of the ADA and the ABA. These standards are maintained by other agencies, including the General Services Administration (GSA) and the U.S. Department of Justice (DOJ). In 2005, GSA adopted new standards based on the guidelines that apply to most federally funded facilities covered by the ABA (except postal, military, and housing facilities, which are covered by standards issued by other agencies). DOJ and the U.S. Department of Transportation (DOT) are responsible for updating standards for facilities covered by the ADA according to the guidelines.

Architectural Barriers Act

The Architectural Barriers Act (ABA), enacted in 1968, requires access to facilities designed, built, altered or leased by Federal agencies. It also applies to certain facilities financed by Federal grants or loans. The law covers a wide range of facilities, including Federal courthouses. The ABA is the first law passed by Congress to require access to the built environment by people with disabilities. Facilities that pre-date the law generally are not covered.

Four federal agencies maintain the standards used to enforce the ABA. Those adopted by the General Services Administration (GSA) apply to Federal courthouses and all other federally funded facilities covered by the ABA except postal, military, and housing facilities. In November 2005, GSA adopted a new accessibility standard based on the

updated guidelines developed by the Access Board. The new ABA Accessibility Standard (ABAAS), which took effect May 9, 2006, for new construction and alterations, replaces the Uniform Federal Accessibility Standards (UFAS). UFAS continues to apply to facilities where the plans and specifications were substantially completed on or before May 8, 2006 if the construction or alteration commences by May 8, 2008.

The Access Board enforces the ABA by investigating complaints concerning particular facilities. The first step of an investigation is to determine whether the facility is covered by the law. Where a facility is covered by the ABA, the next step is to verify whether the facility meets the applicable accessibility standards. If it does not, then the Access Board will work with the responsible entities to develop a plan to bring the facility into compliance. Cases are closed only after the necessary corrective action is completed. The standards and other information on the ABA are available at www.access-board.gov.

Americans with Disabilities Act

Title II of the Americans with Disabilities Act (ADA), enacted in 1990, requires state and local governments to make all of their programs, services, and activities, when viewed in their entirety, accessible to people with disabilities. New construction or alterations to facilities covered by Title II, which include state and local courthouses, must comply with the ADA Accessibility Standards for Accessible Design, adopted by DOJ in 1992. In addition, Title II imposes non-architectural obligations, such as effective communication and reasonable modification of policies on state and local government agencies. DOJ will update the standards in the future according to the new ADA-ABA Accessibility Guidelines issued by the Access Board.

The DOJ has enforcement responsibilities for all programs, services, and activities relating to law enforcement and the administration of justice, including state and local courts and correctional institutions. Under Title II, an administrative complaint concerning a state or local courthouse may be filed with the DOJ or a lawsuit may be filed in Federal district court. If an individual files an administrative complaint, the DOJ will investigate the allegations of discrimination. Should the agency conclude that the public entity violated Title II, it will attempt to negotiate a settlement with the public entity to remedy the violations. Where voluntary compliance cannot be achieved, the complaint may be referred for litigation.

Section 504 of the Rehabilitation Act

Section 504 of the Rehabilitation Act of 1973 covers access to programs or activities that receive Federal financial assistance. Most state and local courthouses are subject Section 504. The substantive standards adopted for ADA Title II (see below) are generally the same as those required under Section 504, but Title II does not displace any existing Section 504 jurisdiction. Section 504 requires courthouses constructed or altered since its effective date to be fully accessible, as well as requiring other activities to provide accessible programs effective communication, and inclusion of people with disabilities.

Section 504 provides covered entities the option of complying with either the Uniform

Federal Accessibility Standards (UFAS) or the ADA Standards for Accessible Design. However, the choice cannot be made on an element-by-element basis, but the chosen standard must be applied consistently to the entire facility.

Individuals may file discrimination complaints with the DOJ against courthouses receiving Federal financial assistance. The DOJ will process those complaints under existing procedures for enforcing Section 504. Under Section 504, fund termination is an enforcement option. In situations where Title II provides greater protection of the rights of individuals with disabilities, DOJ will also apply the substantive requirements established under Title II in processing complaints covered by both Title II and Section 504. DOJ will enforce both Title II and Section 504 for recipients that are also public entities. An individual with a complaint against a Federally-funded courthouse may also file a private lawsuit in court under Section 504.

National Historic Preservation Act

Section 106 of the National Historic Preservation Act may apply to existing structures or sites located in local or State districts or listed or eligible for listing on the National Register of Historic Places. While inclusion or eligibility for listing on the National Register does not exempt a facility from compliance with accessibility requirements, it may result in a modification of those requirements to the extent that they would adversely affect historic elements, as determined by the State Historic Preservation Officer.

References and Sources

www.ADA.gov

www.ncsc.org/courthouseplanning/needs-of-persons-with-disabilities

www.adata.org/factsheet/parking

www.rhodeslaw.com/courtroom/

www.access-board.gov/files/ada/guides/surfaces.pdf

www.themobilityresource.com/blog/post/10-correct-ways-to-interact-with-people-with-disabilities/

www.codes.iccsafe.org/content/IBC2018P5/chapter-11-accessibility

www.ncsc.org/courthouseplanning

www.access-board.gov/ada/guides/chapter-1-using-the-ada-standards/

www.myparkingsign.com/blog/ada-handicapped-parking-rules-access-signs-regulations/

www.ada-compliance.com/ada-compliance/208-and-502-parking-spaces

adacompliancepros.com/ada-guidelines-for-bathroom-accessibility/

www.access-board.gov/files/advisory-committee-reports/caac-report.pdf

www.oba.org/getmedia/356f08da-5c70-4c91-afca-5b55396e16f2/b8naipaul13.pdf

www.inspectionsada.com/ada-compliance-blog/2020/12/18/accessible-means-of-egress-and-the-ada

www.georgiacourts.gov/wp-content/uploads/2019/09/ADA-Judicial-Handbook-2017_Oct-Update.pdf

Design for Accessibility: A Cultural Administrator's Handbook, National Endowment for the Arts

2010 ADA Standards for Accessible Design

Guidance on the 2010 ADA Standards for Accessible Design

DISCLAIMER

This manual is a resource provided by Disability Rights Mississippi and the Mississippi Access to Justice Commission. It is intended to be a guide; it is not a legal document and may not contain every accessibility scenario.

If you have further questions about courthouse accessibility, contact Disability Rights Mississippi at 601-698-0600.

DISABILITY RIGHTS MISSISSIPPI
www.drms.ms
601-968-0600

MISSISSIPPI ACCESS TO JUSTICE COMMISSION
www.msatjc.org
601-960-9581



————— JUSTICE *for* ALL —————